



**PSD TECHNICAL  
SPECIFICATION**

**DIVISION 26  
Electrical**

**Table of Contents**

SECTION 26 01 00 – General Requirements .....	1
SECTION 26 01 10 - Operation and Maintenance of Medium-Voltage Electrical Distribution.....	2
SECTION 26 01 20 - Operation and Maintenance of Low-Voltage Electrical Distribution.....	3
SECTION 26 01 26 – Maintenance Testing of Electrical Systems.....	4
SECTION 26 05 00 – Common Work Results of Electrical .....	5
SECTION 26 05 26 – Grounding and Bonding for Electrical Systems .....	7
SECTION 26 05 29 - Hangers and Supports of Electrical Systems.....	8
SECTION 26 05 33 - Raceway and Boxes of Electrical Systems.....	9
SECTION 26 05 33.13 - Conduit for Electrical Systems.....	10
SECTION 26 05 33.23 - Surface Raceways for Electrical Systems.....	11
SECTION 26 05 39 - Underfloor Raceway for Electrical Systems.....	11
SECTION 26 05 53 - Identification for Electrical Systems.....	12
SECTION 26 05 83 - Wiring Connections.....	13
SECTION 26 12 00 – Medium Voltage Transformers .....	14
SECTION 26 24 00 – Panelboards.....	15
SECTION 26 27 26 - Wiring Devices.....	16
SECTION 26 32 00 – Packaged Generator Assemblies .....	17
SECTION 26 51 00 - Interior Lighting.....	18
SECTION 26 51 13 - Incandescent Interior Lighting.....	21
SECTION 26 51 16 - Fluorescent Interior Lighting.....	21
SECTION 26 51 19 - LED Interior Lighting.....	22
SECTION 26 51 23 - HID Interior Lighting.....	23
SECTION 26 52 13.13 - Emergency Lighting.....	23
SECTION 26 52 13.16 - Exit Signs.....	24
SECTION 26 56 00 - Exterior Lighting.....	25
SECTION 26 56 13 - Lighting Poles and Standards.....	26
SECTION 26 56 19 - LED Exterior Lighting.....	27
SECTION 26 57 00 – Programmable Lighting Control System.....	27
SECTION 26 58 00 – Auditorim Black Box Theatre Performance Lighting System .....	29

## **SECTION 26 01 00 – GENERAL REQUIREMENTS**

### **Part 1: General**

#### **1.01 Summary**

- A. Electrical design and installation shall, as a minimum, use the most recent applicable versions or regulatory requirements of the following:
  - 1. Federal and State regulations.
  - 2. OSHA
  - 3. ANSI/ NFPA 70 (National Electrical Code) as adopted by the AHJ
  - 4. NEMA
  - 5. IEEE
  - 6. ANSI
  - 7. ANSI/ IEEE C2 – National Electrical Safety Code (NEC)
  - 8. Local Protective Signaling Systems
  - 9. NFPA 72A
  - 10. Fire Detection in Mechanical Systems
  - 11. NFPA – 90A
  - 12. NFPA – 101A
  - 13. Life Safety Code

#### **1.02 INTENT**

- A. These technical specifications are for guidance only. These guidelines are founded on considerable design and maintenance experience with the intent of reducing future maintenance problems and extending the trouble-free life of expensive equipment. With these overall goals in mind, the consulting engineers should apply these design priorities consistent with budget constraints:
  - 1. Occupant safety
  - 2. Low life cycle cost of equipment including maintenance and energy
  - 3. Low first cost
- B. All substitutions/changes from this document require the approval of the PSD Electrical Department.

#### **1.03 MATERIALS**

- A. All materials shall be brand new and current production runs. No close-out items are allowed.

#### **1.04 WARRANTY**

- A. A one-year warranty shall include all electrical lamps.
- B. All work, labor and materials shall carry a two-year written warranty. Warranty period shall start on the date of the Poudre School District's final acceptance.

#### **1.05 AS-BUILT DRAWINGS**

- A. Use the red-lined drawings maintained by the Contractor during construction.
  - 1. One-line diagram(s) with revised load calculation.
  - 2. Accurate routing of wiring.
  - 3. Locations of panels and loads.
  - 4. Point-to-point connection diagrams.
  - 5. Accurately locate buried conduit.
  - 6. Accurate circuit connection designations.

#### **1.06 SCHEMATIC DIAGRAMS**

- A. Include schematic diagrams and point-to-point wiring diagrams for the following systems.
  - 1. Clock systems.
    - i. New construction master/synchronous clocks are done by IT dept

2. Electrical systems control.
3. Fire detection/ alarm systems.
4. Lighting/ dimming control systems.
5. Medium voltage equipment.
6. Motor control systems.
7. Kitchen hood fire control panel.
8. Communication system (rough-in)
9. Security systems (rough-in)
10. Stage lighting systems.
11. Sound systems.

## **Part 2: GENERAL DESIGN GUIDELINES**

### **2.01 General**

- A. Provide dual level switching or dimmable LED Fixtures in classroom and office areas
- B. Do not design corridor receptacles or custodial use receptacles on classroom or office circuits.
- C. Provide receptacles at maximum 30' on center in corridors.
- D. Receptacles for school kitchen point of sale (POS) shall be on a dedicated circuit with isolated ground.
- E. Avoid kitchen POS locations in floors. Try and locate on wall or columns. Conduit and floor boxes in slabs are prohibited unless there is a written approval from the PSD Project Manager.
- F. Coordinate placement of receptacles for TV's, overhead projectors, smartboards, etc. as necessary.
- G. Do not locate any electrical panels or switchgear in areas accessible to students.
- H. Provide receptacle outlets in the following areas. Small Rooms: One duplex receptacle at door 48" AFF, Custodian Closet, Mechanical Rooms, Storage Areas. Large Mechanical Rooms: One duplex on all walls 48" AFF.
- I. New branch circuits needing a neutral, installed from the panelboard shall have an individual neutral wire installed for the circuit. Sharing a neutral in multi-wire branch circuits is not permitted.

## **Part 3: INSTALLATION**

### **3.01 General**

- A. Include in the O&M manual certifications received with any electrical equipment and data for any equipment tests performed.
- B. Pour 4"-thick reinforced concrete housekeeping pads to support major equipment like main power transformers and switchgear.
- C. Label main electrical gear with the name, voltage, phase, amp rating, source, and destination of power.

### **3.03 Cleaning and Protection**

- A. Remove construction debris and leave areas broom clean after construction. In electrical rooms, the MDC shall be vacuumed and contacts dusted.

**END OF SECTION 26 01 00**

## **SECTION 26 01 10 – Operation and Maintenance of Medium-Voltage Electrical Distribution**

**Part 1: General**

1.01 Summary

- A. Voltage considered for this section is 277/ 480V - 3Ø:
- B. Standard Electrical System Phase Colors:
  - 1. ØA – Brown
  - 2. ØB – Orange
  - 3. ØC – Yellow
  - 4. Neutral – Gray
  - 5. Ground – Green

1.02 Related Sections

1.03 Definitions

1.04 Submittals

1.05 Quality Assurance

1.06 Scheduling

1.07 Delivery, Storage, and Handling

1.08 Regulatory Requirements

**Part 2: Products**

2.01 Manufactures

2.02 Products

**Part 3: Execution**

3.01 Preparation

3.02 Installation

3.03 Cleaning and Protection

- A. See Section 26 01 00 – General Requirements, Part 3 – Cleaning and Protection, 3.03

**END OF SECTION 26 01 10**

**SECTION 26 01 20 – Operation and Maintenance of Low-Voltage Electrical Distribution**

**Part 1: General**

1.01 Summary

- A. Voltage considered for this section is 120/ 208V - 3Ø:
- B. Standard Electrical System Phase Colors:
  - 1. ØA – Black
  - 2. ØB – Red
  - 3. ØC – Blue
  - 4. Neutral – White
  - 5. Ground – Green

1.02 Related Sections

1.03 Definitions

1.04 Submittals

1.05 Quality Assurance

1.06 Scheduling

1.07 Delivery, Storage, and Handling

1.08 Regulatory Requirements

**Part 2: Products**

2.01 Manufactures

2.02 Products

**Part 3: Execution**

3.01 Preparation

3.02 Installation

3.03 Cleaning and Protection

- A. See Section 26 01 00 – General Requirements, Part 3 – Cleaning and Protection, 3.03

**END OF SECTION 26 01 20**

**SECTION 26 01 26 – MAINTENANCE TESTING OF ELECTRICAL SYSTEMS**

**Part 1: General**

1.01 Summary

- A. Test electrical systems for continuity of circuits, proper insulation resistance, overload settings, rotation of motors, phasing, satisfactory completion of connections and splices, and other conditions to insure that the systems are satisfactory for operation.

1.02 Related Sections

1.03 Definitions

1.04 Submittals Required

- A. Test Reports:

1.05 Quality Assurance

1.06 Scheduling

1.07 Delivery, Storage, and Handling

1.08 Regulatory Requirements

**Part 2: Products**

2.01 Manufactures

2.02 Products

**Part 3: Execution**

3.01 Preparation

- A. Specified tests shall be performed and witnessed by a School District Electrical Department Representative as a requirement for final payment. Explain the functions and demonstrate the operation of major equipment. Tests to be run on the following systems (minimum 1 hour per system):

1. Fire alarm.
2. Clock system.
3. Emergency generator system
4. Exterior lighting controls

- 5. Other special systems.
  - 6. Special lighting system
- 3.02 Installation
- A. When the installation of all apparatus and wiring is complete, test all electrical conductors to insure continuity, freedom from grounds and insulation resistance values.
  - B. Set and adjust all overload devices to suit the load conditions and tests made to determine actual loads.
  - C. All feeders and branch circuits rated below 600 volts shall be megger tested between phase conductors and between phase conductors and ground, using a 1,000-volt megger. Tests shall be made upon completion of all connections and splices and insertion of all overcurrent devices. Tests shall indicate freedom from short circuits and grounds.
  - D. Include a power quality survey for power factor after installation to ensure no system issues (e.g., power factor is satisfactory). The survey should be done with varying load (e.g., a light to heavy range).
  - E. Make all tests in the presence of the Owner's Representative. Contractor shall notify the Owner's Representative in writing seven calendar days prior to testing of the time, place and type of tests to be performed.
  - F. All components, both singularly and as a whole, shall be adjusted and left in a satisfactory operating condition.
  - G. Contractor shall submit a written report of the results of all electrical tests.
- 3.03 Cleaning and Protection
- A. See Section 26 01 00 – General Requirements, Part 3 – Cleaning and Protection, 3.03

**END OF SECTION 26 01 26**

**SECTION 26 05 00 – COMMON WORK RESULTS OF ELECTRICAL**

**Part 1: General**

- 1.01 Summary
- 1.02 Related Sections
- 1.03 Definitions
- 1.04 Submittals
- 1.05 Quality Assurance
- 1.06 Scheduling
- 1.07 Delivery, Storage, and Handling
- 1.08 Regulatory Requirements

**Part 2: Products**

- 2.01 Manufactures
- 2.02 Products
  - A. Clocks: Clocks are located in Division 27 53 13. But for the purposes of the PSD Electrical Department maintaining, supplying and replacing clocks that are not a part of the newer intercom/ clock system the manufacturer and part numbers are listed below for the convenience of information:
    - 1. Synchronous Clocks:
      - a. American Time & Signal: 10" Round, 120V, Flush Mount, U45baaa504 (Lincoln MS)
      - b. American Time & Signal: 12" Round, 24V, Flush Mount, U55baba504

- c. American Time & Signal: 12" Round, 120V, Flush Mount, U55baaa504
  - d. Franklin Instrument Company (Fort Collins High School) Model: F125MA  
BLK F08/ 10, 24VDC/ ma (BIPI) Min. Impulse
2. Digital Clocks:
    - a. New constructed building clocks are spec'd in Div. 27
    - b. American Time & Signal: 4" rectangle, 24V, DSY441RSB3 (Webber)
    - c. Simplex, 4" rectangle, 120V, Celestra 2000, 6334-9140 (Blevins)
  3. 120V or Battery Operated Clocks:
    - a. American Time & Signal: 12" Round, 120V plug-in surface mount, E56baav304
    - b. American Time & Signal: 12" Round, Battery w/ booster pack, E56baqd304bf
    - c. American Time & Signal: 12" Round, Atomic Surface Mount, E55band501
    - d. American Time & Signal: 12" Round, Battery Surface Mount, E56baqd304
  4. Wire Guards:
    - a. American Time & Signal: 16.5"x7.25"x5", G2091 (FRHS)
  5. Back-boxes (surface or flush) to match clock being used.

### Part 3: Execution

#### 3.01 Preparation

#### 3.02 Installation

#### *Special Note:*

**Modular Buildings: Modular specs are located in Division 13 34 23. This is the electrical excerpt for modular buildings.**

#### Part 1: General

##### 1.01 Summary

- A. All installation of wiring shall follow PSD Technical Specifications.

##### 1.02 Related Sections

- A. Division 13 34 23

#### Part 2: Products

#### Part 3: Execution

##### 3.02 Installation

- A. Electrical services for future temporary buildings must be terminated in 36" traffic rated vault.
- B. Vaults
  1. Coordinate location of two vaults in an area close to where such buildings might be placed.
    - a. One (1) 36" vault- Electrical Power
    - b. One (1) 36" vault- Special Systems
- C. Label vaults on the backside of vault cover with the panel label ID and electrical room number from where power is fed.
- D. Extend adequate empty conduit (s) from the main building Comm/Data room (s).
- E. Underground Conduit Sizes
  1. One (1)- 2" conduit for Electrical Power.
  2. One (1)- 1" conduit for Fire Alarm.
  3. Two (2)- 2" conduit for IT/Data.
- F. Label all underground conduits where they are fed from and/ or where they feed to on each end of the conduit run.
- G. Install pull string in each empty conduit.



#### H. Raceway and Boxes for Electrical Systems

1. 3/8" flex or MC is not allowed for use except for use of fixture whips.
2. Single gang steel boxes w/ bracket are not allowed for the use of device outlets. (Switches, Receptacles etc.) 4" square box w/ bracket and plaster ring are the PSD approved method.
3. J-boxes shall be a minimum of 2-1/8" deep 4" sq. box with combo 1/2" & 3/4" concentric KO's.

#### I. Wire Connectors

1. Push-on wire connectors are not allowed for use. (This does not include the manufacturers push-in connector used as the ballast disconnect in a lighting fixture)

#### A. Motors:

1. No contactors, transformers, or control devices to be located above ceilings. Unless approved by PSD Electrical Department.
2. Phase Protection: All motors using 3-phase power and 3-phase air conditioning units shall have protection for phase reversal, loss of phase, or phase unbalance of 10% voltage drop or greater on any one phase.
3. Provide proper rotation of all motors.

#### B. Wire:

1. Minimum wire size:
  - a. #12 AWG for power and lighting circuits.
  - b. #14 AWG for control and signal circuits.
2. Conductor type:
  - a. Conductors #10 AWG and larger, shall be stranded copper.
  - b. Conductors #12 AWG can be solid or stranded copper.
  - c. Conductors #14 AWG can be solid or (stranded copper, depending on application.)
  - d. Conductors smaller than #14, can be solid copper or stranded.
3. Wire sizing:
  - a. For 20 ampere 120V circuits longer than 75', use #10 AWG conductors.
  - b. For 20 ampere 277V circuits longer than 150', use #10 AWG conductors.
  - c. For circuit amperes other than 20 ampere and for distances greater than listed above, calculate voltage drop and size conductors for maximum three (3) percent voltage drop from last overcurrent device.
4. Purple or Pink wire is the preferred color for the load side of switches. (Switch leg)

#### 3.03 Cleaning and Protection

- A. See Section 26 01 00 – General Requirements, Part 3 – Cleaning and Protection, 3.03

**END OF SECTION 26 05 00**

### **SECTION 26 05 26 – GROUNDING AND BONDING FOR ELECTRICAL SYSTEMS**

#### **Part 1: General**

- 1.01 Summary
- 1.02 Related Sections
- 1.03 Definitions
- 1.04 Submittals

- 1.05 Quality Assurance
- 1.06 Scheduling
- 1.07 Delivery, Storage, and Handling
- 1.08 Regulatory Requirements

**Part 2: Products**

- 2.01 Manufactures
- 2.02 Products

A. Grounding System:

1. Provide separate grounding conductor in all raceways.
2. Provide separate grounding jumpers from grounding screw of all receptacle devices to metallic box in which it is mounted. Jumpers may be attached to the box with a separate grounding screw. No ground clip devices are allowed.
3. Provide separate bonding conductor in all runs to exterior lighting standards; i.e. post lights, signs, etc.
4. All conductors used for grounding and bonding purpose shall be copper bare or insulated green only.
5. Provide a separate grounding jumper for all dielectric unions in a fresh water system of the same size as main service ground.
6. Neutral/ground bonding point shall be done within transformers for secondary distribution systems.

**Part 3: Execution**

- 3.01 Preparation
- 3.02 Installation
- 3.03 Cleaning and Protection
  - A. See Section 26 01 00 – General Requirements, Part 3 – Cleaning and Protection, 3.03

**END OF SECTION 26 05 26**

**SECTION 26 05 29 – Hangers and Supports for Electrical Systems**

**Part 1: General**

- 1.01 Summary
- 1.02 Related Sections
- 1.03 Definitions
- 1.04 Submittals
- 1.05 Quality Assurance
- 1.06 Scheduling
- 1.07 Delivery, Storage, and Handling
- 1.08 Regulatory Requirements

**Part 2: Products**

- 2.01 Manufactures
- 2.02 Products

### **Part 3: Execution**

#### 3.01 Preparation

#### 3.02 Installation

##### A. Anchors:

1. Only anchors that use removable bolts or screws are allowed. Screw type anchors approved for the application will be the only type of fastener accepted. Anchors shall be used and approved for use per manufacturer instructions. Examples listed.
  - a. **Drywall:** Molly, E-Z anchor (drywall screw in type), toggle bolt and other.
  - b. **Masonry, block, concrete:** Plastic, lead w/ machine screw bolt, drop-in and other.
  - c. Nail in or Pin type anchors **shall not** be used to mount fixtures, straps, boxes, or any device associated with the electrical system.

#### 3.03 Cleaning and Protection

- A. See Section 26 01 00 – General Requirements, Part 3 – Cleaning and Protection, 3.03

**END OF SECTION 26 05 29**

### **SECTION 26 05 33 – Raceway and Boxes for Electrical Systems**

#### **Part 1: General**

- 1.01 Summary
- 1.02 Related Sections
- 1.03 Definitions
- 1.04 Submittals
- 1.05 Quality Assurance
- 1.06 Scheduling
- 1.07 Delivery, Storage, and Handling
- 1.08 Regulatory Requirements

#### **Part 2: Products**

- 2.01 Manufactures
- 2.02 Products

#### **Part 3: Execution**

##### 3.01 Preparation

##### 3.02 Installation

##### A. Boxes:

1. J-boxes in boiler rooms, mech./elect. rooms, storage rooms or above ceilings shall be a minimum of 2-1/8" deep 4" sq. boxes w/ combo 1/2" & 3/4" concentric KO's.
2. Any boxes in public areas shall be cast weather-proof type or surface raceway (E.g. Wiremold, mid-depth 5748)
3. One extension box is permitted on remodel work to extend existing installations. Where more than one box is needed to flush out installation, provide a larger (i.e. 6" x 6" minimum) box to flush out the existing box and nipple over to a new box.

### 3.03 Cleaning and Protection

**END OF SECTION 26 05 33**

#### **SECTION 26 05 33.13 – Conduit for Electrical Systems**

##### **Part 1: General**

- 1.01 Summary
- 1.02 Related Sections
- 1.03 Definitions
- 1.04 Submittals
- 1.05 Quality Assurance
- 1.06 Scheduling
- 1.07 Delivery, Storage, and Handling
- 1.08 Regulatory Requirements

##### **Part 2: Products**

- 2.01 Manufactures
- 2.02 Products

##### **Part 3: Execution**

- 3.01 Preparation
- 3.02 Installation
  - A. Conduit:
    - 1. Electrical metallic tubing (EMT) "thinwall" shall not be embedded in poured concrete floors, walls, or roofs. AC, MC, and flexible conduit shall not be used for branch circuits or feeders.
    - 2. All underground conduit runs must be rigid conduit 12" below grade to 48" above grade before transitioning to other styles of conduit.
    - 3. PVC conduit is prohibited above ground.
    - 4. Label all spare conduits on the ends as to where it originates and terminates. Install pull string in each empty conduit. (Exception: it is not necessary to label spare conduits that are stubbed for future use directly above an electrical panel.)
  - B. Flexible Conduit:
    - 1. No MC or AC cable is allowed for use unless approved for use by a PSD electrician for a specific project.
    - 2. ½" flex is minimum size to be used.

### 3.03 Cleaning and Protection

- A. See Section 26 01 00 – General Requirements, Part 3 – Cleaning and Protection, 3.03

**END OF SECTION 26 05 33.13**

## **SECTION 26 05 33.23 – Surface Raceways for Electrical Systems**

### **Part 1: General**

- 1.01 Summary
- 1.02 Related Sections
- 1.03 Definitions
- 1.04 Submittals
- 1.05 Quality Assurance
- 1.06 Scheduling
- 1.07 Delivery, Storage, and Handling
- 1.08 Regulatory Requirements

### **Part 2: Products**

- 2.01 Manufactures
- 2.02 Products

### **Part 3: Execution**

- 3.01 Preparation
- 3.02 Installation
  - A. Use medium depth box -1 ¾" (E.g.- Wiremold 5748) as standard unless for specific reasons a shallower or deeper box would be more practical.
  - B. Use 2-hole straps in all areas of the building. *\*A one-hole strap may be used if it is above the ceiling. No clip type straps are allowed in student accessible areas.*
- 3.03 Cleaning and Protection
  - A. See Section 26 01 00 – General Requirements, Part 3 – Cleaning and Protection, 3.03

**END OF SECTION 26 05 33.23**

## **SECTION 26 05 39 – Underfloor Raceways for Electrical Systems**

### **Part 1: General**

- 1.01 Summary
- 1.02 Related Sections
- 1.03 Definitions
- 1.04 Submittals
- 1.05 Quality Assurance
- 1.06 Scheduling
- 1.07 Delivery, Storage, and Handling
- 1.08 Regulatory Requirements

### **Part 2: Products**

- 2.01 Manufactures
- 2.02 Products
  - A. Floor boxes for cast-in-place concrete floors:
    - 1. Prohibited without written approval from PSD.

2. Must be fully adjustable, Cast Iron, Formed Gavanized Steel or Plastic. (PSD acceptable floor boxes and covers listed below. If listed boxes and covers are not available, all substitutions must be approved by the PSD Electrical Dept.)
3. Listed Parts as follows:
  - a. Wiremold/Legrand 4-compartment cast iron combination floor box: RFQ4-CI-1
    1. FPBTBK: Black hard floor cover
    2. FPCTCBK: Black carpet flange cover
  - b. Wiremold/Legrand: 'Walker' Modulink plastic gangable floor box: 880MP2
    1. 880MPA: Nonmetallic floor box adjusting ring
    2. 827PCC-BLK: Two-gang nonmetallic carpet flange (black)
    3. 828PR-BLK: Nonmetallic duplex cover plate (black)
    4. 829PCK-BLK: Nonmetallic communication cover plate (black)
4. Front face shall be perpendicular to the floor to prevent entrance of liquids and debris.

**Part 3: Execution**

3.01 Preparation

3.02 Installation

- A. Must be fully adjustable, Cast Iron, Formed Galvanized Steel or Plastic. (PSD acceptable floor boxes and covers listed below. If listed boxes and covers are not available, all substitutions must be approved by the PSD Electrical Dept.)

3.03 Cleaning and Protection

**END OF SECTION 26 05 39**

**SECTION 26 05 53 – Identification for Electrical Systems**

**Part 1: General**

1.01 Summary

1.02 Related Sections

1.03 Definitions

1.04 Submittals

1.05 Quality Assurance

1.06 Scheduling

1.07 Delivery, Storage, and Handling

1.08 Regulatory Requirements

**Part 2: Products**

2.01 Manufactures

2.02 Products

**Part 3: Execution**

3.01 Preparation

3.02 Installation

- A. All electrical panels and equipment shall be labeled. All labels shall be engraved plastic, white letters on black background. Labels shall be attached with screws or rivets. No pressure-sensitive adhesives will be allowed.
- B. The following equipment shall have a plastic nameplate with a minimum letter height of 1/4":
  - 1. Main Service Feeder Switch or Circuit Breaker.
  - 2. Sub-distribution Equipment.
  - 3. Main Switchboard and Panel.
  - 4. All Sub-distribution Panelboards and Special Equipment and Boxes.
- C. The following equipment shall have a plastic nameplate with a minimum letter height of 3/16":
  - 1. Each separately mounted disconnect and starter for a motor or fixed appliance.
  - 2. Nameplate shall also provide the motor designation, voltage, and phase. (Panel and circuit #)
- D. The following equipment shall have a plastic nameplate with a minimum letter height of 1/4":
  - 1. All branch circuit panelboards, complete with voltage and phase.
  - 2. All branch circuit panelboards shall have their directories neatly typed.
- E. All switches that control mechanical equipment, pumps, fans, boilers, etc., shall have plastic nameplates with a minimum letter height of 1/8".
- F. Device covers (receptacles, switches) shall be labeled neatly with a permanent marker or label maker with panel & circuit number. (ex. L1A-10)
- G. On the cover of each junction box and pull box: the circuit number(s) of the enclosed conductors are to be legibly written with a black permanent ink broad tip marking pen and the system identification.
- H. All disconnects & motor starters shall be labeled with panel and circuit number.
- I. Panelboard directories shall be labeled with the actual **finished** building room numbers for circuit identification and not the room numbers from the construction plans. (Unless they are the same)

3.03 Cleaning and Protection

- A. See Section 26 01 00 – General Requirements, Part 3 – Cleaning and Protection, 3.03

**END OF SECTION 26 05 53**

**SECTION 26 05 83 – Wiring Connections**

**Part 1: General**

- 1.01 Summary
- 1.02 Related Sections
- 1.03 Definitions
- 1.04 Submittals
- 1.05 Quality Assurance
- 1.06 Scheduling
- 1.07 Delivery, Storage, and Handling
- 1.08 Regulatory Requirements

**Part 2: Products**

- 2.01 Manufactures

## 2.02 Products

### **Part 3: Execution**

#### 3.01 Preparation

#### 3.02 Installation

##### A. Devices

1. If a device (switch, receptacle, etc.) is terminated with stranded wire (14, 12 or 10 gauge) a crimp-on type terminal is required.

##### B. Tying into Existing 'Live' Circuits

1. When tying into a live circuit of a multi-wire circuit the electrical contractor doing the work will be responsible for damage to electronic equipment if a neutral wire accidentally or inadvertently gets 'opened-up'. Otherwise the circuit should be shut off which may require scheduling a time with other classrooms or offices affected by the circuit being turned off.
2. Leave splices long enough to tap for future use. If new wires are being run through a box, leave a loop big enough to splice into at a later date.

##### C. Wire Connectors

1. Push-on wire connectors are not allowed for use. This does not include the push-in connector used as a lighting disconnect from a fixture whip to a ballast or LED driver in the fixture.

#### 3.03 Cleaning and Protection

- A. Wiring scraps and stripped insulation shall be swept clean from the floor.
- B. Wiring scraps shall not be left on top of the ceiling tiles.

**END OF SECTION 26 05 83**

## **SECTION 26 12 00 – MEDIUM VOLTAGE TRANSFORMERS**

### **Part 1: General**

#### 1.01 Summary

#### 1.02 Related Sections

#### 1.03 Definitions

#### 1.04 Submittals

#### 1.05 Quality Assurance

#### 1.06 Scheduling

#### 1.07 Delivery, Storage, and Handling

#### 1.08 Regulatory Requirements

- A. Comply with US Department of Energy's Candidate Standard Level three (CSL-3).
- B. Comply with IEEE-519.
- C. Exceed National Electric Code related requirements.
- D. Exceed NEMA TP-1.

### **Part 2: Products**

#### 2.01 Manufactures



- A. Powersmiths International Corporation or PSD approved equal
- 2.02 Products
  - A. T1000-C3 or PSD approved equal

**Part 3: Execution**

- 3.01 Preparation
- 3.02 Installation
  - A. Provide built-in surge suppression and enhanced energy efficient harmonic cancellation.
  - B. Provide 25 year warranty.
- 3.03 Cleaning and Protection
  - A. See Section 26 01 00 – General Requirements, Part 3 – Cleaning and Protection, 3.03

**END OF SECTION 26 12 00**

**SECTION 26 24 00 – PANELBOARDS**

**Part 1: General**

- 1.01 Summary
- 1.02 Related Sections
- 1.03 Definitions
- 1.04 Submittals
- 1.05 Quality Assurance
- 1.06 Scheduling
- 1.07 Delivery, Storage, and Handling
- 1.08 Regulatory Requirements

**Part 2: Products**

- 2.01 Manufactures
  - A. Panelboard manufacturers:
    - 1. Square D
    - 2. Siemens/ ITE
- 2.02 Products

**Part 3: Execution**

- 3.01 Preparation
- 3.02 Installation
  - A. General:
    - 1. Install 3/4" conduit from electric meter(s) to main com/data room.
    - 2. Install 3/4" conduit from gas meter(s) to main com/data room.
    - 3. Install 3/4" conduit from water meter(s) to main com/data room.
  - B. Main Distribution Center shall be installed on a 4" housekeeping curb, wall mounted, with a maximum height of 90" to the top of the equipment from finished floor, level and plumb.
  - C. Install nameplates identifying main distribution center, AIC rating, voltage, amps, phase, all branch loads and main devices.
  - D. Provide locks with two keys furnished per lock. All panels keyed alike.
  - E. Door-in-door type front panel construction with nameplate mounted on front of panel.

- F. Install nameplates identifying main distribution center, AIC rating, voltage, amps, phase, all branch loads and main devices.
  - G. Furnish typewritten directory boards to identify each circuit. Note spare circuits on directory cards in pencil.
  - H. Label each breaker within a panel as to type of circuit and area served with room numbers.
  - I. Locate in a dedicated lockable room.
  - J. Main Distribution Switchboard/Panelboards: Copper or tin-plated aluminum bus bars. Prefer Square D or approved equal by PSD Electrical Department.
  - K. Safety Switches: Heavy-duty type fusible or nonfusible, NEMA rating for environment installed. Prefer Square D or approved equal.
  - L. Transformers shall be high efficiency type. (PowerSmith to be approved) Sound levels shall not exceed level listed by ANSI-C89. Transformers to be mounted with additional isolation pads and electrical connections made with flexible conduit.
  - M. Electrical services to include 25% spare capacity for future. Extend service to exterior location directed by School District for each future modular building site and terminate in vault.
  - N. Provide 25% spare capacity and space in all branch circuit panels.
  - O. Provide 3 spare fuses for each size installed. Provide appropriate size spare fuse cabinet to store spare fuses.
  - P. Label all spare conduits on each end as to where it originates and terminates. Install pull string in each empty conduit.
- 3.03 Cleaning and Protection
- A. See Section 26 01 00 – General Requirements, Part 3 – Cleaning and Protection, 3.03

**END OF SECTION 26 24 00**

**SECTION 26 27 26 – Wiring Devices**

**Part 1: General**

- 1.01 Summary
- 1.02 Related Sections
- 1.03 Definitions
- 1.04 Submittals
- 1.05 Quality Assurance
- 1.06 Scheduling
- 1.07 Delivery, Storage, and Handling
- 1.08 Regulatory Requirements

**Part 2: Products**

- 2.01 Manufactures
- 2.02 Products
  - A. Cover Plates:
    - 1. Metal cover plates shall be used on all flush devices.
  - B. Receptacles:
    - 1. All receptacles in schools shall be tamper-resistant.
    - 2. Receptacles shall be 20A commercial grade. Duplex receptacles shall be extra heavy-duty tamper resistant type with nylon fronts and backs.

3. Corridor receptacles shall be High Abuse Type Hubbell, Arrowhart, or P&S on approximately 30' centers.
  4. Devices must be pigtailed from branch circuit for ease of device removal or replacement.
  5. Wires tying into existing receptacles must tie into the branch circuit pigtail and not the screw terminals of the receptacle.
  6. The ground wire shall be pigtailed to the box with a 10/32 green screw and wrapped on the grounding screw/ yoke of the device. Grounding clips or the bonded screw in the yoke are not considered sufficient for use in PSD.
  7. All unused screws on the receptacles or switches shall be in the tightened position.
- C. Switches:
1. Switches shall be extra heavy-duty type with nylon fronts and backs.
  2. Keyed switches shall be P&S 20AC1-L Series. No exceptions.
  3. Devices must be pigtailed from branch circuit for ease of device removal or replacement.
  4. Switches for life safety circuits shall be red.

**Part 3: Execution**

3.01 Preparation

3.02 Installation

3.03 Cleaning and Protection

- A. See Section 26 01 00 – General Requirements, Part 3 – Cleaning and Protection, 3.03

**END OF SECTION 26 27 26**

**SECTION 26 32 00 – PACKAGED GENERATOR ASSEMBLIES**

**Part 1: General**

1.01 Summary

1.02 Related Sections

1.03 Definitions

1.04 Submittals

1.05 Quality Assurance

1.06 Scheduling

1.07 Delivery, Storage, and Handling

1.08 Regulatory Requirements

**Part 2: Products**

2.01 Manufactures

- A. Approved manufacturers: 1<sup>st</sup> Preference: Kohler, 2<sup>nd</sup> Preference: Onan.

2.02 Products

**Part 3: Execution**

3.01 Preparation

3.02 Installation

- A. Poudre School District standard for providing emergency standby power; Package to include the following.
  - 1. Transfer switch equipped with an adjustable exercise clock that does not require the time/exercise to be programmed through a laptop computer.
  - 2. Remote annunciator – location to be approved by PSD Electrical Dept.
  - 3. Generator shall run on Natural Gas.
  - 4. Standby generators shall be located on the exterior of the building in an area that will provide adequate access for maintenance personnel and equipment.
  - 5. Generator shall be protected by a fenced enclosure, including a fenced roof.
- B. Emergency Power Systems:
  - 1. Emergency power shall operate the following systems:
    - a. Exit/egress lighting.
    - b. EM Lighting: Main Office, Electrical Room, and Telephone Room.
    - c. Telephone system.
    - d. Intercom system.
  - 2. Existing school remodel and expansions shall match existing systems with the following:
    - a. Provide a complete exit and emergency lighting system.
    - b. Locate all exit lights for maximum visibility.
    - c. Entire system shall comply with NEC.
  - 3. Paint red using enamel spray paint for following: cover-plates, J-boxes, load center, panelboards, and safety switches.

3.03

- A. See Section 26 01 00 – General Requirements, Part 3 – Cleaning and Protection, 3.03

**END OF SECTION 26 32 00**

**SECTION 26 51 00 – Interior Lighting**

**Part 1: General**

1.01 Summary

- A. Daylighting and light quality are considerations. Brightness contrasts are to be avoided. Foot-candles can be less when proper design is achieved, which may change this specification. (See Sustainable Design Guidelines.)

1.02 Related Sections

1.03 Definitions

1.04 Submittals

1.05 Quality Assurance

1.06 Scheduling

1.07 Delivery, Storage, and Handling

1.08 Regulatory Requirements

A. Interior Lighting

- 1. All new lighting shall be LED.
- 2. The maintained lighting levels in all areas is based on information found on-line in ESNA recommended levels.  
[http://eeprograms.net/docs/CLEARresult\\_Gen\\_Lighting\\_Recs.pdf](http://eeprograms.net/docs/CLEARresult_Gen_Lighting_Recs.pdf)

3. Lighting to be designed such that illumination levels fall within a given range, according to the space type. Average lighting levels are not to fall below the range's lower limit and not exceed the range's upper limit. This is to assure all spaces are adequately lit but are not over-lit. The ranges apply to all working areas in space, and should be sustained throughout lamp life. The following foot-candle (fc) ranges are derived primarily from IESNA recommended levels.

<u>Space Type:</u>	<u>Lighting Level Range (fc)</u>
Classroom	30-50
Science Lab	50-70
Library	30-50
Office	30-50
Computer Lab	3-30
Corridor/ Common Space	10-20
Gym (recreational)	30-50
Gym (competition)	50-100
Cafeteria	10-20
Kitchen	30-50
Restroom	5-15
Mechanical Room	20-50

Determined without any deration factors (e.g., dust/dirt, etc.)

4. Luminaire schedule: Provide a luminaire schedule on the design documents to give the following information.
- Luminaire identification.
  - Description (including ballast type).
  - Manufacturer and catalog number.
  - Voltage
  - Lamps (catalog number and type).
  - Mounting with required mounting depth.
  - Input Watts per fixture.
5. Consideration of fixture/ luminaire should include the following:
- Durability: Choose fixtures that will last for many years, and take the abuse of students.
  - Practical: Choose fixtures that can be maintained easily and parts available for many years. (Choose fixtures that will be easy to clean and will keep bugs, paper, pencils, etc...out).
  - Standardize: Choose fixtures with standard lamps and try to reduce the number of different types of lamps the school will have to stock.
6. Fixtures/ Luminaire: New and Replacement:
- New fixtures to be LED unless matching existing lighting fixtures is a consideration for the project area. Use listed fixtures approved by PSD Electrical Department. All others to be approved by PSD Electrical Department.
7. Gym, weight room, flex room, shops – areas with high bay/impact fixtures: Safety cable requirements shown in sketch below. Special install to be reviewed with PSD electrical department.
- If existing suspended lights are removed to be replaced: Contractor is NOT to assume use of existing cables/structure is appropriate for use. Current code to be met and adherence to preferred method of install per sketch below is to govern installation.

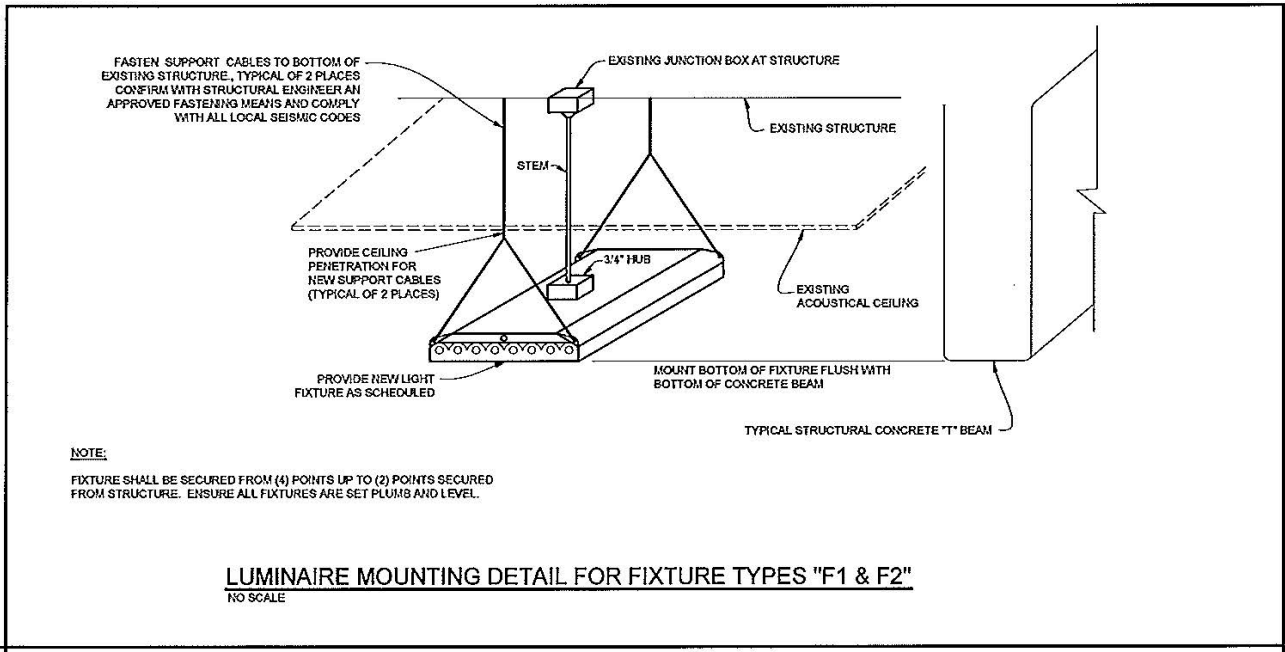

**B. LIGHTING CONTROL**

1. Lighting controls are to be determined in the design process per project. This is a minimal guideline only. (WattStopper standard)
2. Any lighting controlled by occupancy sensors shall have a standard toggle keyed or low volt type switch, located at standard switch location next to the entry door. This switch is to turn off the lights when necessary for the purpose of energy saving and maintenance.
  - a. Switch location mounted occupancy sensors shall not be used unless approved for use by PSD Electrical Dept.
3. Classrooms, instructional areas, and the library shall have multi-level switching. Or approved by PSD Electrical Dept.
4. Gang toilets and locker room lights shall operate from ceiling mounted motion switches overridden (to turn off) by keyed switches. Faculty restroom lighting shall be controlled by standard toggle switches.
5. Corridor lighting shall be controlled by toggle switches located in janitor closet or keyed switches in hallway. Gym lighting shall be controlled by local wall switch. Provide night lighting in corridors, un-switched, connected to emergency panel, and permanently identified on the interior of the fixtures.

**Part 2: Products**

- 2.01 Manufactures
- 2.02 Products

**Part 3: Execution**

- 3.01 Preparation
- 3.02 Installation
  - A. Wall-pack fixtures shall be hung with metal or lead type expanding anchors with a minimum of ¼" machine screw to fasten on masonry walls; \*plastic or drive-in 'button head' nail type wedge anchors are not to be used.
  - B. Fixtures mounted on drywall shall use toggle bolts or screwed into wall stud or other framing member. Use of screw-in type anchors is not permitted. (E.g.: E-Z anchor)

3.03 Cleaning and Protection

- A. See Section 26 01 00 – General Requirements, Part 3 – Cleaning and Protection, 3.03

**END OF SECTION 26 51 00**

**SECTION 26 51 13 – Incandescent Interior Lighting**

**Part 1: General**

1.01 Summary

- A. Incandescent Lamps: Shall not be used in any areas.

1.02 Related Sections

1.03 Definitions

1.04 Submittals

1.05 Quality Assurance

1.06 Scheduling

1.07 Delivery, Storage, and Handling

1.08 Regulatory Requirements

**Part 2: Products**

2.01 Manufactures

2.02 Products

**Part 3: Execution**

3.01 Preparation

3.02 Installation

3.03 Cleaning and Protection

- A. See Section 26 01 00 – General Requirements, Part 3 – Cleaning and Protection, 3.03

**END OF SECTION 26 51 13**

**SECTION 26 51 16 – Fluorescent Interior Lighting**

**Part 1: General**

1.01 Summary

1.02 Related Sections

1.03 Definitions

1.04 Submittals

1.05 Quality Assurance

1.06 Scheduling

1.07 Delivery, Storage, and Handling

1.08 Regulatory Requirements

**Part 2: Products**

2.01 Manufactures

## 2.02 Products

- A. Lamps: Shall be 32w, 3500K or 4100K to match existing lamps in building.
- B. Ballasts: Shall be instant start electronic, Sylvania Quicktronic: QHEx32T/ UNV ISL-SC-B
- C. Ballasts shall be high efficiency per applicable rebate requirements.
- D. Gym Fixtures:
  - 1. Lithonia: I-beam, 24L WD SD125 LP740 DLC OUTCTR WGX, MVOLT
  - 2. GE: Albedo LED Luminaire, High Bay Lighting (ABV-Series)
- E. Troffer Fixtures: Lithonia 2x4 troffer, 3500k (LP835) or 4000k (LP840), LBL4
- F. Wraparound Fixtures: Lithonia 1x4, 3500k (LP835) or 4000k (LP840), LBL4
- G. Custodial closets and other smaller spaces: Lithonia LED Flush Mount, Versi Lite, FMML, 7" or 13", 830 (3000K) or 840 (4000K)
- H. All other fixture/ luminaire styles and types to be approved by the PSD Electrical Department.

## Part 3: Execution

### 3.01 Preparation

### 3.02 Installation

- A. Stairways: No fixtures are allowed above the stairs.
  - 1. Mount fixtures on walls at landings 8'-0" max. above finished landing.

### 3.03 Cleaning and Protection

- A. See Section 26 01 00 – General Requirements, Part 3 – Cleaning and Protection, 3.03

## END OF SECTION 26 51 16

## SECTION 26 51 19 – LED Interior Lighting

### Part 1: General

#### 1.01 Summary

- A. Fixtures/ Luminaire: New and Replacement:
  - 1. New fixtures to be LED unless matching existing lighting fixtures is a consideration for the project area. Use listed fixtures approved by PSD Electrical Department. All others to be approved by PSD Electrical Department.

#### 1.02 Related Sections

#### 1.03 Definitions

#### 1.04 Submittals

#### 1.05 Quality Assurance

#### 1.06 Scheduling

#### 1.07 Delivery, Storage, and Handling

#### 1.08 Regulatory Requirements

### Part 2: Products

#### 2.01 Manufactures

#### 2.02 Products

### Part 3: Execution



- 3.01 Preparation
- 3.02 Installation
  - A. All storage areas, custodial rooms, and other support areas shall use LED wraparound fixture
- 3.03 Cleaning and Protection
  - A. See Section 26 01 00 – General Requirements, Part 3 – Cleaning and Protection, 3.03

**END OF SECTION 26 51 19**

**SECTION 26 51 23 – HID Interior Lighting**

**Part 1: General**

- 1.01 Summary
  - A. Metal Halide: Shall not be used unless approved by the PSD Electrical Department.
- 1.02 Related Sections
- 1.03 Definitions
- 1.04 Submittals
- 1.05 Quality Assurance
- 1.06 Scheduling
- 1.07 Delivery, Storage, and Handling
- 1.08 Regulatory Requirements

**Part 2: Products**

- 2.01 Manufactures
- 2.02 Products

**Part 3: Execution**

- 3.01 Preparation
- 3.02 Installation
- 3.03 Cleaning and Protection
  - A. See Section 26 01 00 – General Requirements, Part 3 – Cleaning and Protection, 3.03

**END OF SECTION 26 51 23**

**SECTION 26 52 13.13 – Emergency Lighting**

**Part 1: General**

- 1.01 Summary
- 1.02 Related Sections
- 1.03 Definitions
- 1.04 Submittals
- 1.05 Quality Assurance
- 1.06 Scheduling
- 1.07 Delivery, Storage, and Handling

## 1.08 Regulatory Requirements

### **Part 2: Products**

#### 2.01 Manufactures

#### 2.02 Products

### **Part 3: Execution**

#### 3.01 Preparation

#### 3.02 Installation

A. EM lighting fixtures shall not use built-in or remote battery pack batteries as a back-up power source: See exceptions below-

- *Exceptions:*

1. The building does not have an emergency generator used for a back-up EM power source.
2. The building is a modular building or a separate building away from the main building with no EM power run to the building from the generator.

B. All new EM lighting fixtures installed must tie into the building EM power or the automated building EM lighting control system, unless noted above in exceptions.

#### 3.03 Cleaning and Protection

A. See Section 26 01 00 – General Requirements, Part 3 – Cleaning and Protection, 3.03

## **END OF SECTION 26 52 13.13**

### **SECTION 26 52 13.16 – Exit Signs**

#### **Part 1: General**

##### 1.01 Summary

##### 1.02 Related Sections

##### 1.03 Definitions

##### 1.04 Submittals

##### 1.05 Quality Assurance

##### 1.06 Scheduling

##### 1.07 Delivery, Storage, and Handling

##### 1.08 Regulatory Requirements

#### **Part 2: Products**

##### 2.01 Manufactures

##### 2.02 Products

A. PSD standard: Light Fixture Industries 33EXST-GW (White Steel housing, Green lettering, AC only) (Note: PSD has ordered them on-line from 'exitlight.com'. 1-2 week delivery time.)

B. All other alternates/ substitutes shall be approved by PSD Electrical Department.

#### **Part 3: Execution**

##### 3.01 Preparation

##### 3.02 Installation

- A. Installed as required by IBC and NFPA
- B. Wire guards shall be installed around exit lights in gyms and multipurpose room.

### 3.03 Cleaning and Protection

- A. See Section 26 01 00 – General Requirements, Part 3 – Cleaning and Protection, 3.03

## END OF SECTION 26 52 13.16

### **SECTION 26 56 00 – Exterior Lighting**

#### **Part 1: General**

##### 1.01 Summary

- A. All complete building replacement of exterior fixtures shall be LED type approved by PSD Electrical Department.
- B. Remodel projects shall try to match existing exterior LED or High Pressure Sodium fixtures if possible or PSD Electrical Department approved.

##### 1.02 Related Sections

##### 1.03 Definitions

##### 1.04 Submittals

##### 1.05 Quality Assurance

##### 1.06 Scheduling

##### 1.07 Delivery, Storage, and Handling

##### 1.08 Regulatory Requirements

###### A. AREA LIGHT CONTROL

1. Tie exterior light circuits into existing PSD 'Building Automation System'
2. IF there is not a 'Building Automation System' installed at the site, tie exterior light circuits into a central digital time clock. Lighting control shall be photo-cell "on" time clock, "off".
  - a. Parking Lot: "On" dusk, "Off" time clock
  - b. Building Security: "On" dusk, "Off" time clock
  - c. Or other method approved by PSD Electrical dept.
3. Photo-Cell:
  - a. Photo-cell shall be roof mounted or high on wall outside of electrical room (Location to be approved by PSD Electrical Department.)
4. Provide manual override in a convenient location for maintenance operation of exterior fixtures by School District Electrician during daylight hours, for maintenance purposes. (Location to be approved by PSD Electrical Department.)
 

Minimum Lighting Levels in Foot-candles (fc): Foot-candle levels are based on general information found on-line for IESNA recommended levels.

  - a. Building Exterior: 1fc
  - b. Main Entrance Areas: 5fc
  - c. Egress Emergency Lighting: 0.5fc
  - d. Parking Areas:
    1. High Schools-
      - \* High Activity (Athletic/ Theatre): 3.5fc

- \* Low Activity (General Parking): 1fc
  - 2. Middle Schools-
    - \* Medium Activity (Athletic): 2.5fc
    - \* Low Activity (General Parking): 1fc
  - 3. Elementary-
    - \* Low Activity (All Parking): 1fc
- e. Average exterior lighting level shall be 1 foot-candle, and no areas shall be less than 0.5 foot-candles.
- 5. Exterior Lamps and Ballasts
  - 6. Exterior lamps shall be dual element high-pressure sodium in HPS fixtures.

**Part 2: Products**

2.08 Manufactures

A. Lighting Contactors:

- 1. 120 or 277 volt, 20 amp, multipole, electrically held NEMA 1 enclosure.

B. Approved Manufacturers:

- 1. Square D, or approved equal.

2.09 Products

**Part 3: Execution**

3.08 Preparation

3.09 Installation

3.10 Cleaning and Protection

- A. See Section 26 01 00 – General Requirements, Part 3 – Cleaning and Protection, 3.03

**END OF SECTION 26 56 00**

**SECTION 26 56 13 – Lighting Poles and Standards**

**Part 1: General**

1.01 Summary

- A. Parking lighting shall be pole mounted. 30' maximum, 12'-0" minimum pole height from finished grade. Install light poles on minimum 24" high concrete pedestals in landscaped areas, and 36" concrete pedestal in parking lots.

1.02 Related Sections

1.03 Definitions

1.04 Submittals

1.05 Quality Assurance

1.06 Scheduling

1.07 Delivery, Storage, and Handling

1.08 Regulatory Requirements

**Part 2: Products**

- 2.01 Manufactures
- 2.02 Products
  - A. (Head Only) RAB Lighting, ALED4T150N

**Part 3: Execution**

- 3.01 Preparation
- 3.02 Installation
- 3.03 Cleaning and Protection

**END OF SECTION 26 56 13**

**SECTION 26 56 19 – LED Exterior Lighting**

**Part 1: General**

- 1.01 Summary
- 1.02 Related Sections
- 1.03 Definitions
- 1.04 Submittals
- 1.05 Quality Assurance
- 1.06 Scheduling
- 1.07 Delivery, Storage, and Handling
- 1.08 Regulatory Requirements

**Part 2: Products**

- 2.01 Manufactures
- 2.02 Products
  - A. PSD approved LED exterior luminaires and pole light fixtures:
    - 1. Wallpacks:
      - a. MaxLite, maxLED 20 Series, 20W, 5000K
      - b. RAB Lighting, Slim26N, 26W, 4000K

**Part 3: Execution**

- 3.01 Preparation
- 3.02 Installation
- 3.03 Cleaning and Protection
  - A. See Section 26 01 00 – General Requirements, Part 3 – Cleaning and Protection, 3.03

**END OF SECTION 26 56 19**

**SECTION 26 57 00 – PROGRAMMABLE LIGHTING CONTROL SYSTEM**

## **Part 1: General**

### 1.01 Summary

- A. In general the system shall control all building lighting.
- B. Lighting control system shall utilize networking technology to be integrated with the Building Automation System. (BAS)
- C. Lighting control system shall have override switches. (The number and location of override switches to be determined in the design process) The override switches shall be capable of turning lights 'ON', bypassing the photo-cell and Building Automation System. (Previous Lighting Control System specs/systems used in the District are available by contacting PSD - PD&C representative.)
- D. Minimum lighting levels of all areas to be determined in design process.
- E. Electrical contractor shall be familiar with all system components and the associated requirements prior to submitting a bid.

### 1.02 Related Sections

### 1.03 Definitions

### 1.04 Submittals Required

- A. Overall Building Shop Drawings
- B. System Component Shop Drawings
- C. Typical Wiring Diagrams
- D. Testing, Operation, Maintenance Data

### 1.05 Quality Assurance

- A. Source Limitations:
  - 1. Obtain lighting control devices from a single source.
- B. Manufacturers:
  - 1. Firms regularly engaged in manufacture of lighting control equipment whose products have been in satisfactory use in similar service for not less than five years.
- C. System Support:
  - 1. Factory-authorized technician or factory-authorized service representative shall be available for onsite training as well as telephone support.

### 1.06 Scheduling

### 1.07 Delivery, Storage, and Handling

### 1.08 Regulatory Requirements

## **Part 2: Products**

### 2.01 Manufacturers

- A. Acceptable Manufacturer: Douglas Lighting Controls or approved equal.

### 2.02 Products

- A. Submit shop drawings on programmable lighting controller & components for approval.

## **Part 3: Execution**

### 3.01 Preparation

### 3.02 Installation

- A. Provide all necessary software to integrate the lighting control system with the building automation system. (BAS)
- B. Program timeclock functions according to Owner representative(s) desired settings.
- C. Demonstration
  - 1. Provide a factory-authorized technician or factory-authorized service representative to train PSD Electrical Department personnel as specified below.

- a. Troubleshooting, servicing, adjusting, and preventive maintenance.
- b. Programming of the lighting control system.
- c. Provide a minimum of three hours training.

3.03 Cleaning and Protection

- A. See Section 26 01 00 – General Requirements, Part 3 – Cleaning and Protection, 3.03

**END OF SECTION 26 57 00**

**SECTION 26 58 00 – AUDITORIUM BLACK BOX THEATRE PERFORMANCE LIGHTING SYSTEM**

**Part 1: General**

1.01 Summary

- A. The work shall include supply and installation of new equipment components and instruments for the performance lighting system, including house lighting control equipment.
- B. Furnish engineering checkout and instruction in the use of the lighting control systems specified herein.
- C. Support the Theatrical Systems Installing Contractor by providing demonstration and user training.
- D. Installation and integration of this equipment shall be by the Theatrical Systems Installing

1.02 Related Sections

1.03 Definitions

1.04 Submittals Required

- A. Shop Drawings
- B. Submit elevations of control room and dimmer room wall showing equipment locations to be coordinated the A/V System Installing Contractor, the Contractor and Electrical.
- C. On completion of installation, provide project record documents and complete operation manuals.

1.05 Quality Assurance

- A. The dimming, control and associated equipment specified herein shall have been continuously engaged in the manufacture of theatrical lighting, dimming and control equipment for at least ten (10) years.
- B. WARRANTY:
  - 1. Guarantee all components to be free of defects in material and workmanship for a period of two (2) year from date of final acceptance.
  - 2. Paint and exterior finishes, fuses and lamps are excluded from above guarantees except when damage or failure results from defective materials or workmanship covered by the guarantee.
- C. SERVICE:
  - 1. Replace defective materials and repair faulty workmanship within 48 hours of discovery at no cost to the Owner.
  - 2. If during a period of two (2) year from date of final acceptance, any component is out of service for more than one week, due to unavailability of parts or service within that period, supply and install an identical new component. If an identical component is not available, substitute equivalent equipment, but only with the approval of the Owner.

1.06 Scheduling

1.07 Delivery, Storage, and Handling

## 1.08 Regulatory Requirements

### Part 2: Products

#### 2.01 Manufactures

#### 2.02 Products

A. The performance lighting system shall include, but not be limited to, the following:

**1. Auditorium Dimmer and Control Equipment:**

- a. Electronic Theatre Controls Sensor+ SineWave
- b. Electronic Theatre Controls Sensor+
- c. Strand Lighting C21 Advanced Technology Dimmer System
- d. Approved Equals meet the standards of SineWave or IGBT dimming

**2. Distribution Equipment:**

- a. All plug strip circuit members shall be identified by 2" high presson letters, silk screening or paint-filled engraving on the strip in 2-inch high contrasting numerals.
- b. All circuits shall have 18-inch pigtails, except as noted, 2 pole, 3 wire stage pin connectors and double pipe hangers. Provide junction boxes and terminal boxes as required. Field verify all dimensions prior to fabrication.

**3. Auditorium Lighting Instruments:**

- a. Lighting instruments shall be complete with 2 pole, 3 wire stage pin connectors, color frame, lens, lamp, C-clamp and safety cables.
- b. Description Manufacturer Model No. Qty.
- c. Ellipsoidals: Electronic Theatre Controls Source 4 or approved equal
- d. Zoom Ellipsoidals: Electronic Theatre Controls Source 4 or approved equal
- e. Fresnels: Electronic Theatre Controls PARnel or approved equal
- f. PAR Altman PAR64/8 CF/P64 SS 24 or approved equal
- g. 12 Medium & 12 Wide
- h. Skycyc Altman SKY-CYC-03 4 or approved equal
- i. Followspot Lycian Midget 1209 2 or approved equal

**4. Lamps:**

- a. Provide one (1) lamp per instrument plus 20% spares, minimum of six (6) spares. For Xenon lamps provide 100% spares.

**5. Miscellaneous:**

### Part 3: Execution

#### 3.01 Preparation

#### 3.02 Installation

A. DEMONSTATION AND TRAINING:

1. The engineer in conjunction with the Theatrical System Installing Contractor shall provide at least four (4) hours of instruction on the programming, operation, maintenance and troubleshooting of the system.

#### 3.03 Cleaning and Protection

A. See Section 26 01 00 – General Requirements, Part 3 – Cleaning and Protection, 3.03

**END OF SECTION 26 58 00**