

OLANDER ELEMENTARY SCHOOL

EARLY CHILDHOOD RESTROOM PROJECTS



POUDRE SCHOOL DISTRICT
OLANDER ELEMENTARY SCHOOL
5401 AUNTIE STONE STREET
FORT COLLINS, CO 80526



No.	Revision	Date

Sheet Title:
COVER

Project
EC REST ROOMS
CONSTRUCTION SET
Date
03/02/2020
Scale
Sheet
G000

ARCHITECT

CRUMPTON AND ASSOCIATES, ARCHITECTS
 12891 JACKSON CIRCLE
 THORNTON, CO 80241
 PHONE: 720.427.5421
 FAX: NA

CIVIL CONSULTANT

STRUCTURAL CONSULTANT

MECHANICAL CONSULTANT

DESIGN POINT ENGINEERING, LLC
 19 OLD TOWN SQUARE SUITE 238
 FORT COLLINS, CO 80524
 PHONE: 970.430.5783
 FAX: NA

ELECTRICAL CONSULTANT

RJ MCNUTT AND ASSOCIATES, LLC
 6801 W 20TH STREET
 GREELEY, CO
 PHONE: 970.330.3266
 FAX: NA

FIRE ALARM CONSULTANT

ABBREVIATIONS

A/C	AIR CONDITIONING	M	MINUTE
AB	ANCHOR BOLT	MAS	MASONRY
ACCESS	ACCESSIBLE	MAT	MAT
ACT	ACROUSTICAL TILE	MAX	MAXIMUM
ADJ	ADJUSTABLE	MB	MARKER BOARD
ATF	ABOVE FINISHED FLOOR	MBM	METAL BUILDING MANUFACTURER
AL	ALUMINUM	MCH	MECHANICAL
ALT	ALTERNATE	MFR	MANUFACTURER
AND	AND	MN	MINUTE
APPROX	APPROXIMATE	MIR	MIRROR
ARCH	ARCHITECTURAL	MR/S	MIRROR W/ SHELF
ASB	ACOUSTIC SOUND BOARD	MSC	MISCELLANEOUS
AMP	ACOUSTICAL WALL PANELS	MEL	MELAMINE
		MO	MASONRY OPENING
		MT	MOUNTED
		MTL	METAL
		MULL	MULLION
BB	BULLETIN BOARD	(N)	NEW
BC	BASE CABINET	NA	NOT APPLICABLE
BD	BOARD	NIC	NOT IN CONTRACT
BTWN	BETWEEN	NOM	NOMINAL
BL	BRICK LEDGE	NPS	NOMINAL PIPE SIZE
BLDG	BUILDING	NIS	NOT TO SCALE
BLDG	BLOCKING	O	OVER/ON
BM	BENCH MARK/BEAM	OA	ON CENTER
BOM	BOTTOM OF MASONRY	OC	OUTSIDE DIAMETER
BOS	BOTTOM OF STEEL	OD	OVERFLOW LEADER
BOT	BOTTOM	OFC	OWNER FURNISHED
BRG	BEARING	OFCI	CONTRACTOR INSTALLED
BRKT	BRACKET	OFS	OWNER INSTALLED
BS	BACKSPLASH	OFD	OVERFLOW DRAIN
BSMT	BASEMENT	OH	OVERHEAD/OPPOSITE HAND
BUR	BUILT-UP ROOF	OPG	OPENING
		OPP	OPPOSITE
C	COURSE(S)	OFB	OVERFLOW BOARD
(C)	CORNER	OC	OWNER FURNISHED
CAB	CABINET	OFS	OWNER INSTALLED
CAB	CABINET	OFD	OVERFLOW DRAIN
CB	CHALKBOARD	OH	OVERHEAD/OPPOSITE HAND
CD	CEMENT BOARD	OPG	OPENING
CF	CUBIC FEET	OPP	OPPOSITE
CG	CORNER GUARD		
CI	CAST IRON		
CIP	CAST-IN-PLACE		
CJ	CONTROL JOINT		
CLG	CENTERLINE		
CLR	CLEAR/CLEARANCE		
CM	CONCRETE		
CMU	CONCRETE MASONRY UNIT(S)		
COL	COLUMN		
CONC	CONCRETE		
CONST	CONSTRUCTION		
CONT	CONTINUOUS/CONTRACTOR		
CPT	CAPRET		
CT	CERAMIC TILE		
CTR	COUNTER/COUNTERTOP		
CY	CUBIC YARD		
D	DEEP/DEPTH		
(D)	DEMOLISHED		
DB	DISPLAY BOARD		
DBL	DOUBLE		
DF	DRAINING FOUNTAIN		
DIAG	DIAGONAL		
DIA	DIAMETER		
DM	DIMENSION		
DN	DOWN		
DS	DOWNSPOUT		
DTL	DETAIL		
DWG	DRAWING		
(E)	EXISTING		
EA	EACH		
EFS	EXTERIOR INSULATION FINISH SYSTEM		
EJ	EXPANSION JOINT		
EL	ELEVATION		
ELEC	ELECTRICAL		
ELEV	ELEVATION		
EMER	EMERGENCY		
EPM	ROOFING SYSTEM RE SPEC.		
EPT	EPOXY PAINT		
EQ	EQUAL		
EQUIP	EQUIPMENT		
EW	EACH WAY		
EWC	ELECTRIC WATER COOLER		
EXH	EXHAUST		
EXP	EXPOSED		
EXT	EXTERIOR		
FA	FIRE ALARM		
FAP	FIRE ALARM PANEL		
FD	FLOOR DRAIN		
FE	FIRE EXTINGUISHER		
FEC	FIRE EXTINGUISHER CABINET		
FN	FINISHED		
FL	FLOOR LINE		
FLR	FLOOR/FLOORING		
FND	FOUNDATION		
FOC	FACE OF CONCRETE		
FOF	FACE OF FINISH		
FOM	FACE OF MASONRY		
FOS	FACE OF STUD(S)		
FR	FIRE-RESISTANT		
FRP	FIBERGLASS REINFORCED PLASTIC		
FS	FLOOR SINK/FINISHED SURFACE		
FT	FOOT/FEET		
FTG	FOOTING		
FUR	FURRING		
G	GAS		
GA	GAUGE		
GALV	GALVANIZED		
GB	GYP/SIM BOARD/GRAB BAR		
GBU	GLASS BLOCK UNIT		
GC	GENERAL CONTRACTOR		
GCMU	GLAZED CMU		
GFCMU	GROUND FACE CMU		
GI	GALVANIZED IRON		
GR	GUARDRAIL		
GYP	GYP/SIM		
H	HEIGHT/HIGH		
HT	HEIGHT		
HB	HOSE BIBB		
HC	HOLLOW CORE		
HDWD	HARDWOOD		
HD	HEAVY DUTY		
HDW	HARDWARE		
HDOP	HANDICAPPED		
HM	HOLLOW METAL		
HDRZ	HORIZONTAL		
HR	HANDRAIL		
HVAC	HEATING VENTILATING AIR CONDITIONING		
ID	INSIDE DIAMETER		
INCL	INCLUDING		
INSUL	INSULATION		
INT	INTERIOR		
INV	INVERT		
J	JOIST BEARING		
JB	JOIST		
JT	JOINT		
L	LENGTH		
LAM	LAMINATE(ED)		
LAV	LAVATORY		
LH	LEFT HAND		
LKR	LOCKER(S)		
LMB	LIQUID MARKER BOARD		
LND	LINOLEUM		
LTC	LIGHTING		
LVR	LOUVER		
M	MINUTE		
MAS	MASONRY		
MAT	MAT		
MAX	MAXIMUM		
MB	MARKER BOARD		
MBM	METAL BUILDING MANUFACTURER		
MCH	MECHANICAL		
MFR	MANUFACTURER		
MN	MINUTE		
MIR	MIRROR		
MR/S	MIRROR W/ SHELF		
MSC	MISCELLANEOUS		
MEL	MELAMINE		
MO	MASONRY OPENING		
MT	MOUNTED		
MTL	METAL		
MULL	MULLION		
(N)	NEW		
NA	NOT APPLICABLE		
NIC	NOT IN CONTRACT		
NOM	NOMINAL		
NPS	NOMINAL PIPE SIZE		
NIS	NOT TO SCALE		
O	OVER/ON		
OA	ON CENTER		
OC	OUTSIDE DIAMETER		
OD	OVERFLOW LEADER		
OFC	OWNER FURNISHED		
OFCI	CONTRACTOR INSTALLED		
OFS	OWNER INSTALLED		
OFD	OVERFLOW DRAIN		
OH	OVERHEAD/OPPOSITE HAND		
OPG	OPENING		
OPP	OPPOSITE		
OFB	OVERFLOW BOARD		
OC	OWNER FURNISHED		
OFS	OWNER INSTALLED		
OFD	OVERFLOW DRAIN		
OH	OVERHEAD/OPPOSITE HAND		
OPG	OPENING		
OPP	OPPOSITE		
FRB	PARTICLE BOARD		
CCC	PRECAST CONCRETE		
PCF	POUNDS PER CUBIC FOOT		
PE	POURED EPOXY		
PL	PLATE		
PLAM	PLASTIC LAMINATE		
PLAS	PLASTER		
PLF	POUNDS PER LINEAR FOOT		
PR	PAIR		
PS	PROJECTION SCREEN		
PSF	POUNDS PER SQUARE FOOT		
PSI	POUNDS PER SQUARE INCH		
PT	PAIN		
PTD	PAPER TOWEL DISPENSER		
PVC	POLYVINYL CHLORIDE		
PWMT	PAVEMENT		
PWD	PLYWOOD		
QT	QUARRY TILE		
(R)	RELOCATE(ED)		
R	RISER/RADIUS/RATED		
RB	RUBBER BASE		
RCMU	RIBBED CMU		
RCP	REFLECTED CEILING PLAN		
RD	ROOF DRAIN		
RDL	ROOF DRAIN LEADER		
RE	REFER TO		
REV	REVERSED		
REINF	REINFORCING		
REQD	REQUIRED		
RFS	ROOM FINISH SCHEDULE		
RH	RIGHT HAND		
RM	ROOM		
RO	ROUGH OPENING		
ROW	RIGHT OF WAY		
RIBBED CMU	RIBBED & SPLIT CMU		
RUBBER TILE OR TREAD	RUBBER TILE OR TREAD		
(S)	SALVAGE(D)		
SACMU	SOUND ABSORBING CMU		
SAT	SUSPENDED ACOUSTICAL TILE		
SC	SOLID CORE		
SCAT	SPRAYED CELLULOSE ACOUSTIC TREATMENT		
SD	STORM DRAIN		
SDT	STATIC DISSIPATIVE TILE		
SECT	SECTION		
SFF	SQUARE FOOT		
SFCMU	SPLIT FACE CMU		
SFT	STRUCTURAL GLAZED TILE		
SHT	SHEET		
SHTG	SHEATHING		
SM	SIMILAR		
SHV	SHREY/SHELVES/SHELVING		
SM	SHEET METAL		
SPECS	SPECIFICATIONS		
SQ	SQUARE		
SS	SANITARY SEWER/STAINLESS STEEL		
ST	STANDARD		
STD	STANDARD		
STRUC	STRUCTURAL		
SUSP	SUSPENDED		
SV	SHEET VINYL		
SYM	SYMMETRICAL		
TD	TRAVEL DISTANCE		
TB	TACKBOARD		
T&B	TOP AND BOTTOM		
T&G	TONGUE AND GROOVE		
TEL	TELEPHONE		
THK	THICK/THICKNESS		
TOB	TOP OF BEAM		
TOC	TOP OF CONCRETE/CURB		
TOM	TOP OF MASONRY		
TOS	TOP OF STEEL		
TOW	TOP OF WALL		
TP	TOP PLATE		
TPD	TOILET PAPER DISPENSER		
TS	TUBE STEEL		
TRIP	TRIP		
TV	TELEVISION		
UC	UPPER CABINET		
UGE	UNDERGROUND ELECTRICAL		
UNO	UNLESS NOTED OTHERWISE		
VB	VENTED BASE		
VCT	VINYL COMPOSITION TILE		
VERT	VERTICAL		
VEST	VESTIBULE		
VF	VINYL FACED		
VFB	VINYL FACED GYP/SIM BOARD		
VF	VERIFY IN FIELD		
VWC	VINYL WALL COVERING		
W	WIDTH/WIDE		
W/	WITH		
W/O	WITHOUT		
WO	WHERE OCCURS		
WB	WOOD BASE		
WH	WATER HEATER/WALL HUNG		
WC	WATER CLOSET		
WN	WINDOW		
WO	WOOD		
WP	WATERPROOF		
WR	WATER RESISTANT		
WT	WELDED WIRE FABRIC		

ARCHITECTURAL SYMBOLS

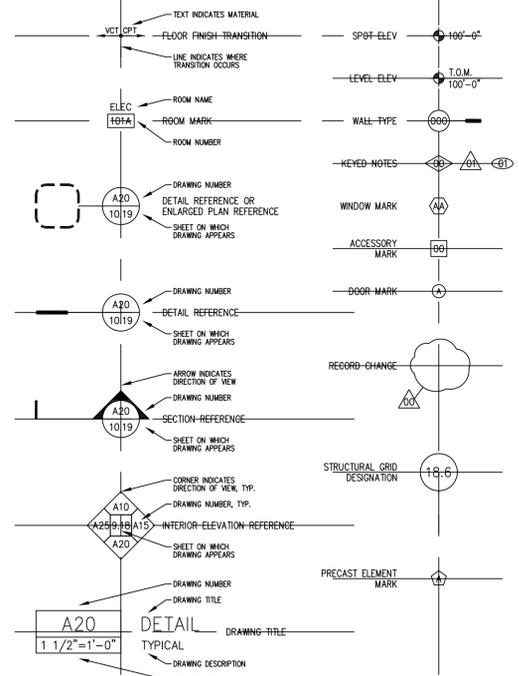

MATERIALS LEGEND

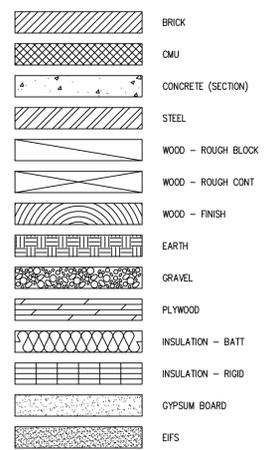

GENERAL NOTES

DEMOLITION WORK INCLUDES NOTES ON ALL SHEETS IN THE FOLLOWING DRAWING SET. THESE SHEETS ARE NOT INTENDED TO BE ALL INCLUSIVE OF THE COMPLETE SCOPE OF REQUIRED DEMOLITION. REMOVE EXISTING CONSTRUCTION REQUIRED FOR ALL WORK INCLUDING NEW MECHANICAL, ELECTRICAL AND PLUMBING SYSTEMS. THE CONTRACTOR IS RESPONSIBLE FOR ALL DEMOLITION AND ASSOCIATED PATCHING / FINISHING REQUIRED TO COMPLETE ALL PHASES OF WORK.

DO NOT SCALE DRAWINGS. FIELD VERIFY ALL DIMENSIONS. NOTIFY ARCHITECT IMMEDIATELY WHEN DISCREPANCIES ARE DISCOVERED.

IT IS THE RESPONSIBILITY OF THE MECHANICAL AND THE ELECTRICAL SUBCONTRACTOR TO REVIEW ALL THE DRAWINGS, INCLUDING ARCHITECTURAL, FOR WORK UNDER THEIR RESPECTIVE CONTRACTS. ROOF PLANS AND REFLECTED CEILING PLANS DESCRIBE MECHANICAL AND ELECTRICAL WORK AS DO OTHER ARCHITECTURAL DRAWINGS. NO EXTRAS WILL BE ALLOWED FOR WORK SHOWN IN ANY PART OF THESE DRAWINGS.

INTERIOR DIMENSIONS ARE FROM FACE OF STUD, FACE OF MASONRY, OR FACE OF CONCRETE (UNLESS NOTED OTHERWISE). WHERE DIMENSION IS NOTED "CLEAR", DIMENSION IS TO FINAL FINISH.

DRAWING INDEX

COVER
 G000 COVER SHEET/CODE PLAN
 G100 SYMBOLS

GENERAL

CIVIL NOT USED

STRUCTURAL
 S1 NOT USED

ARCHITECTURAL
 AD101 DEMO
 A101 PARTIAL FLOOR PLAN
 A301 SCHEDULES AND DETAILS
 A202.1 NOT USED

ELECTRICAL
 ED101 LEGENDS/NOTES
 ED101 DEMO PLAN
 E101 ELECTRICAL PLAN

FIRE
 NOT USED

MECHANICAL
 M001 NOTES AND LEGENDS
 M101 MECHANICAL FLOOR PLAN
 P001 NOTES AND LEGENDS
 P101 PLUMBING FLOOR PLAN
 P301 PLUMBING SCHEDULES AND DETAILS

CODE ANALYSIS:
 CONSTRUCTION II B
 OCCUPANCY IS E
 FULLY SPRINKLED
 CODES USED 2015 IBC LEVEL II, IBC, IFC,
 NEC, AND ANSI 117.1/2009

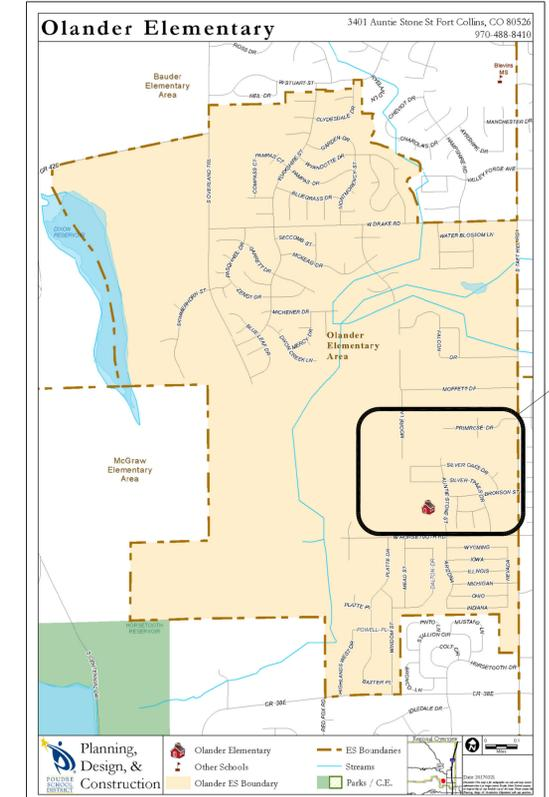

WORK LOC



POUDRE SCHOOL DISTRICT
 OLANDER ELEMENTARY SCHOOL
 5401 AUNTIE STONE STREET
 FORT COLLINS, CO 80526



No.	Revision	Date

Sheet Title:
 GRAPHICS

Project
 EC REST ROOMS
 CONSTRUCTION SET
 Date 03/02/2020 Sheet G100
 Scale

VICINITY MAP

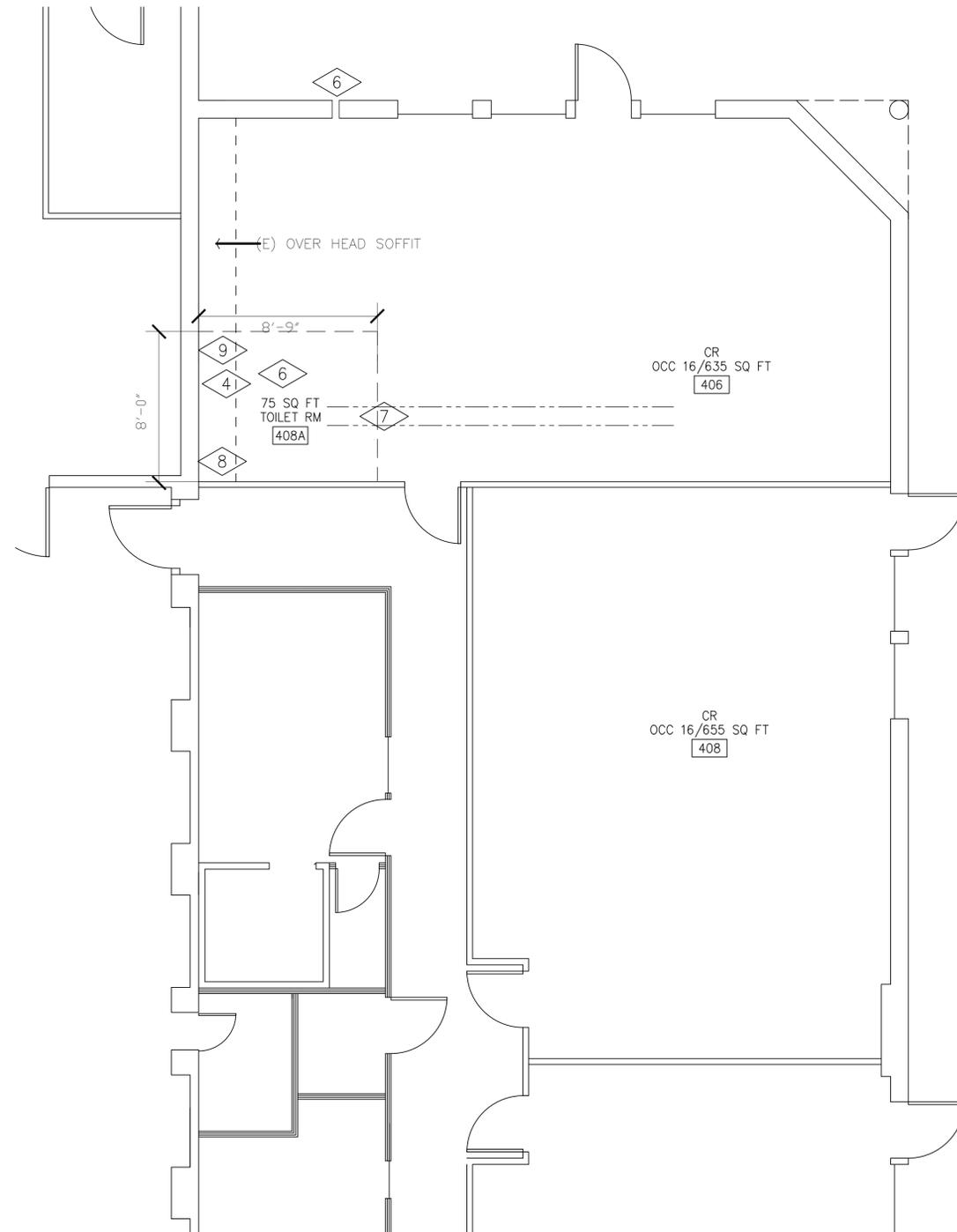

PARTIAL FLOOR PLAN
SCALE IN FEET
0 4 8 16

KEY DEMO NOTES:

- 1 WALL PARTITION, DEMO TO HARD SOFFIT
- 2 R&R SOFT CEILING TO ACCOMMODATE (N) WALLS
- 3 NOT USED
- 4 DEMO FLOOR FOR SANITARY DRAIN SEE P SHEETS
- 5 DEMO ELECTRICAL/LIGHTS SEE E SHEETS
- 6 CUT ROOF DECK FOR EF. REPAIR SEE G1/A301 & H1/A301, M SHEETS
- 7 NOT USED
- 8 DEMO CARPET SALVAGE TO REPAIR CONSTRUCTION DAMAGE.
- 9 MOVE (E) FIRE SPRINKLER HEAD TO INSIDE OF (N) TOILET ROOM. THIS IS DESIGN BUILD GC RESPONSIBILITY.

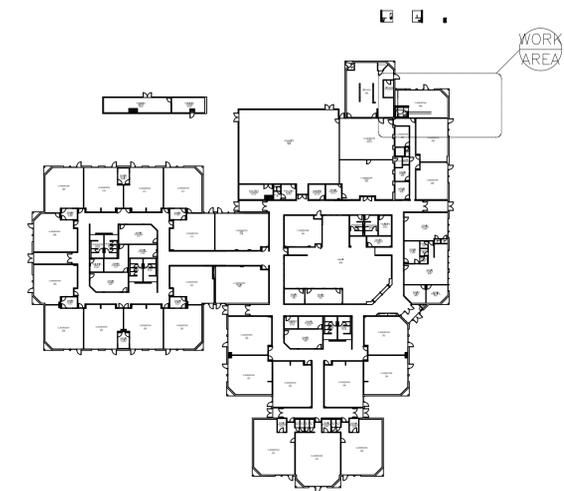

KEY PLAN
NTS



POUDRE SCHOOL DISTRICT
OLANDER ELEMENTARY SCHOOL
5401 AUNTIE STONE STREET
FORT COLLINS, CO 80526



No.	Revision	Date

Sheet Title:
DEMO

Project
EC REST ROOMS
CONSTRUCTION SET
Date
03/02/2020
Scale
Sheet
AD101

KEY NOTES:

- 1 NEW WALLS/CEILING
- 2 (N) FLOOR DRAIN SEE PLUMBING SHEETS
- 3 NEW HARD GYP CEILING INSULATE WITH SOUND ATTENUATION BATTS. SEE B/A301
- 4 PATCH CONCRETE/REPAIR CARPET
- 5 NEW POURED ACRYLIC FLOORS AND INTEGRAL 4" COVE BASE
- 6 MEETS ANSI 117.1/2009 305, 404, AND 606
- 7 RFP GLASBOARD SANITARY PANELS SEC 068316 ALTERNATE 2
4"X12" CERAMIC WALL TILES. DALTILE, WALL COLOR ARTIC WHITE WHITE 0190, OCEAN BLUE 1049 BULL NOSE CAPS.
- 8 FOLDING DIAPER TABLE AND LOCKABLE STORAGE CABINETS
- 9 NOT USED
- 10 (E) BLOCK WALL
- 11 (E) ACT CEILING
- 12 BUILD NEW CEILING UNDER (E) SOFFIT SEE D/A101

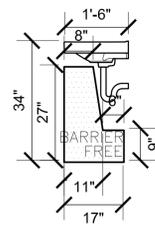

C WALL HUNG SINK SECTION
SCALE 1/2" = 1'-0"

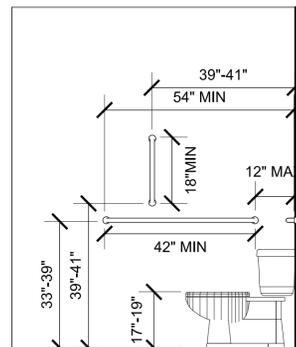

2 WALL ELEVATION
SCALE 1/2" = 1'-0"

MIRROR SPECIFICATIONS: ASI 620 24"X36" TEMPERED GLASS OR EQUAL

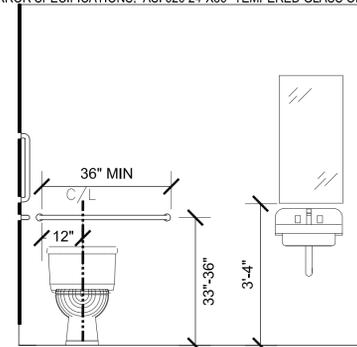

3 WALL ELEVATION
SCALE 1/2" = 1'-0"

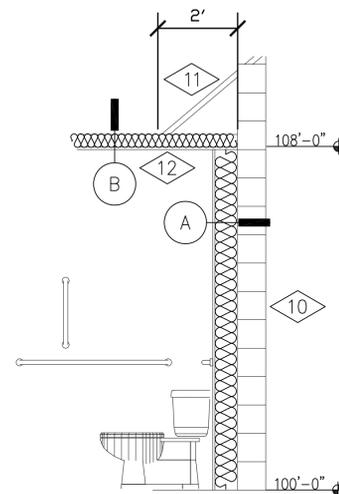

D WALL SECTION
SCALE 1/2" = 1'-0"

WALL TYPE PLUMBING ————— A ———

PLUMBING WALL ASSEMBLY: 7" NOMINAL WALL, 5/8" GYP, SOUND ATTENUATION INSULATION AND METAL 20 GA STUDS 16" OC. TAPE DRYWALL TO A LEVEL 4, PRIME AND PAINT. COLOR TBD.

WALL AND CEILING TYPE ————— B ———

WALL ASSEMBLY: 5" NOMINAL WALL, 5/8" GYP, SOUND ATTENUATION INSULATION AND METAL 20 GA STUDS 16" OC. TAPE DRYWALL TO A LEVEL 4, PRIME AND PAINT. COLOR TBD.
CEILING REQUIRES GYP ONE SIDE ONLY.

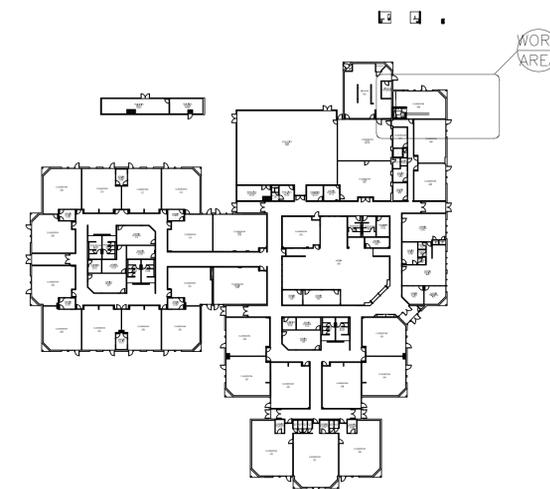
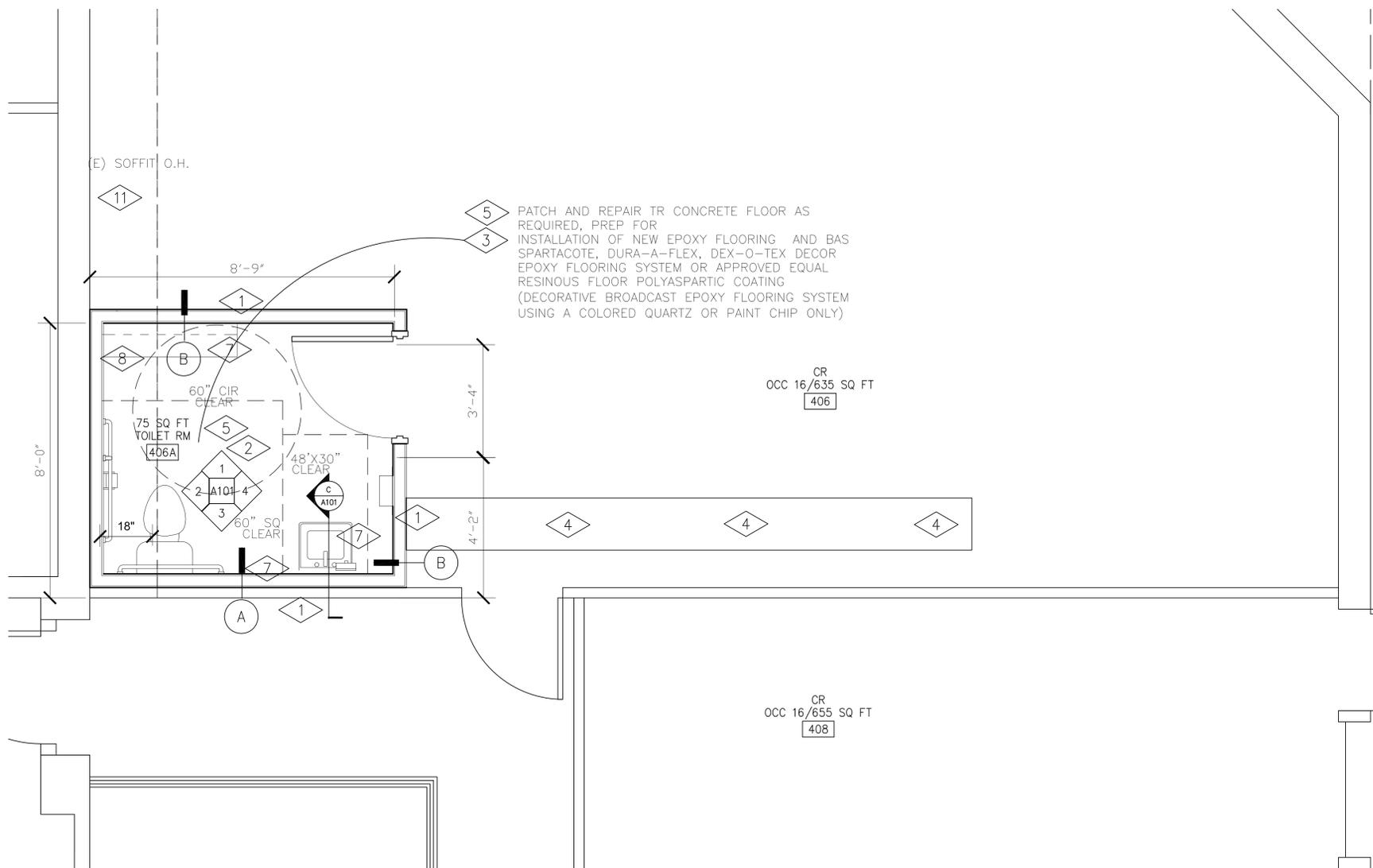

KEY PLAN
NTS



POUDRE SCHOOL DISTRICT
OLANDER ELEMENTARY SCHOOL
5401 AUNTIE STONE STREET
FORT COLLINS, CO 80526



No.	Revision	Date

Sheet Title:
PLAN VIEW

Project
EC REST ROOMS
CONSTRUCTION SET
Date: 03/02/2020 Sheet
Scale: A101

FINISH SCHEDULES

NUM.	ROOM NAME	DOOR TYPES						FRAME TYPES			DETAILS	REMARKS		
		TYPE	MATL	LABEL	HEIGHT	WIDTH	THICK	TYPE	MAT'L	LABEL			THROAT	
406A	TOILET	NEW	WD	NR	7'-0"	3'-0"	1 3/4"	F1	HM	NR	5"	16 GA	NEW DOOR, FRAME AND HARDWARE	
DOOR HARDWARE														
		LOCK SET			HINGES			DOOR STOP			KICK PLATE		SILENCERS	
406A	TOILET	(1) EA PRIVACY LOCKSET ND40SRH O626, 6 PIN CORE			(3) EA HINGES SBBL US32D IVE			(1) EA WALL STOP WS407 CCV US32D IVE			(1) EA KICKPLATE 8400 10"X34" US32D IVE		(1) ONE SET	
WALL PAINT														
406A	TOILET	ONE COAT OF WHITE PRIMER DU-1507 PRO MAX, TWO COATS SEMI-GLOSS LAYTEX BASED DS1695 HEALTH KOTE OR APPROVED EQUAL												
CARPET														
408	CR	TANDUS, MANNINGTON OR MOHAWK ARE APPROVED MANUFACTURERS : MATCH EXISTING. MATERIAL MAY BE SHEET GOODS												

KEYED NOTES

- 1 SOUND ATTENUATING INSULATION 3.5" . OWENS CORNING QUIETZONE
- 2 20 GA METAL STUD
- 3 HM FRAME 16 GA
- 4 PRE-FINISHED CLEAR MAPLE WOOD DOOR 1 3/4" THICK
- 5 PAINT TO MATCH EXISTING FRAME COLOR
- 6 PRIME AND P[AIN]T NEW WORK IMPACTED BY THE CONSTRUCTION
- 7 RFP GLASBOARD SANITARY PANELS SEC 068316 OR ALTERNATE 1 4"X12" CERAMIC WALL TILES. DAL TILE, WALL COLOR ARTIC WHITE WHITE 0190, OCEAN BLUE 1049 BULL NOSE CAPS.
- 8 5/8" TYPE X GYP

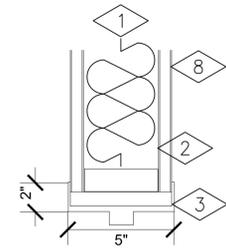

F1 JAMB PROFILE
SCALE 3" = 1'-0"

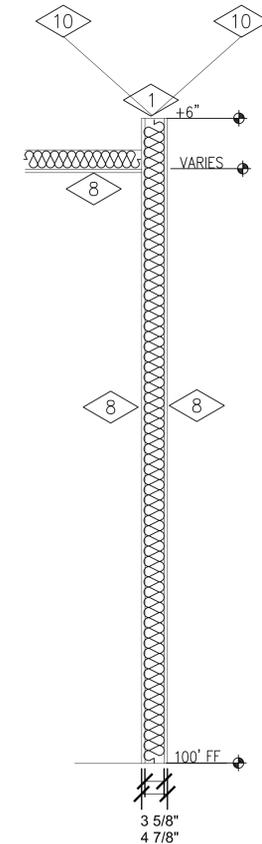

B NEW WALL/SECTION TYP
SCALE 3/4" = 1'-0"

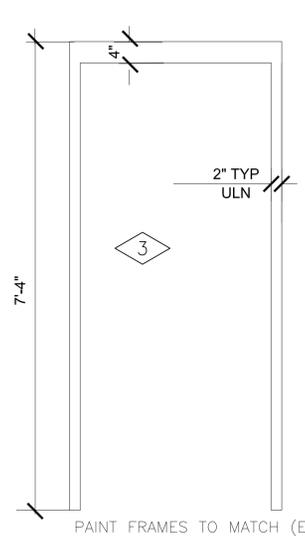

F1 PAINT FRAMES TO MATCH (E)
SCALE 3/4" = 1'-0"

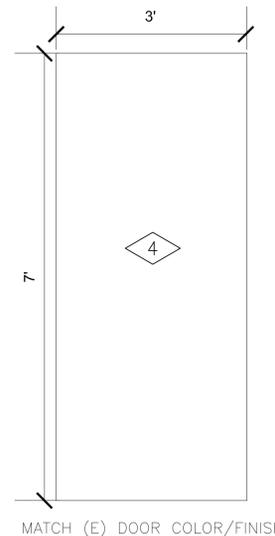

WD MATCH (E) DOOR COLOR/FINISH
SCALE 3/4" = 1'-0"

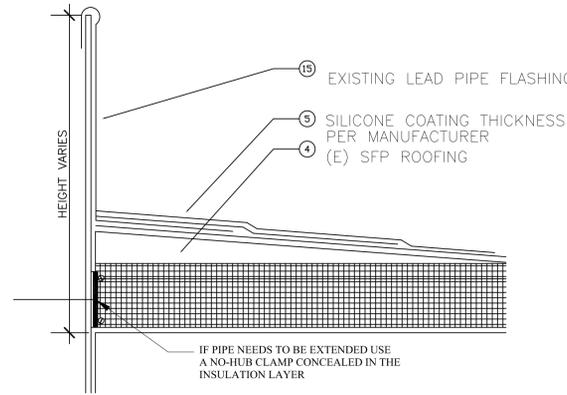

G1 SPF SOIL STACK SECTION DETAIL
SCALE 3" = 1'-0"

- 4) TAPERED EDGE SET IN HOT ASPHALT OR MECHANICALLY FASTENED.
- 5) 5 COURSE STRIPPING (PLASTIC CEMENT, FABRIC, PLASTIC CEMENT, FABRIC, PLASTIC CEMENT).
- 15) LEAD JACK, PRIME, SET IN PLASTIC CEMENT, STRIP IN WITH COTTON FABRIC AND PLASTIC CEMENT 5 COURSE STYLE.

CONTRACTOR TO COORDINATE AND VERIFY ROOF PENETRATION OCCURS IN THE FLAT PORTION OF THE ROOF

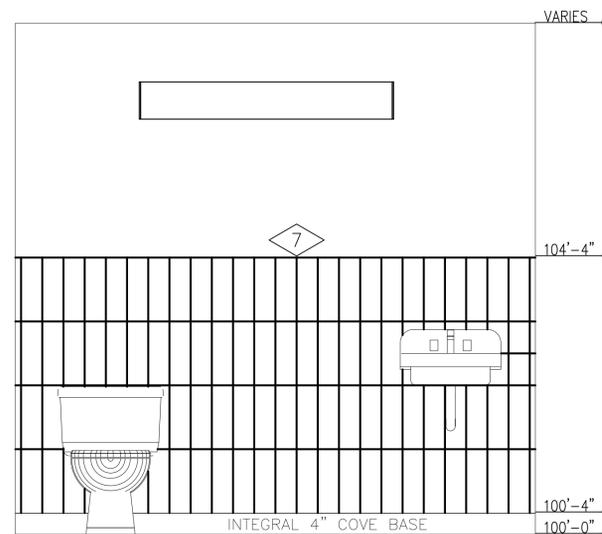

3 TYP WALL ELEVATIONS(4)
SCALE 3/4" = 1'-0"

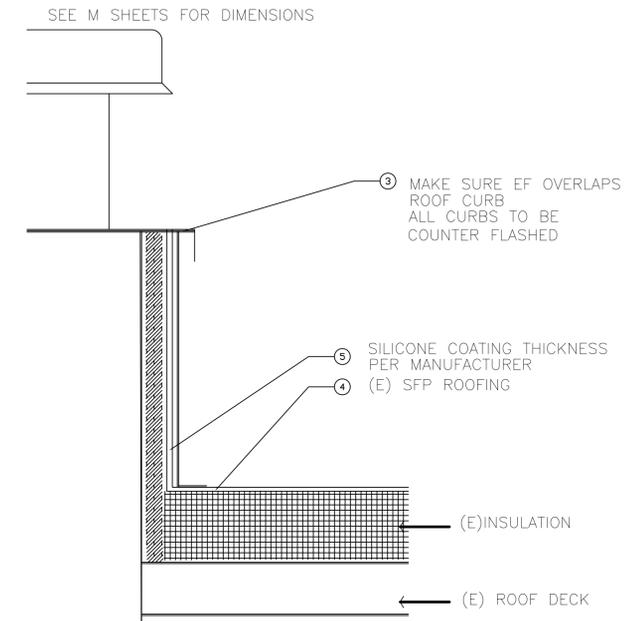

H1 EF SPF ROOF DETAIL
SCALE 3" = 1'-0"



POUDRE SCHOOL DISTRICT
OLANDER ELEMENTARY SCHOOL
5401 AUNTIE STONE STREET
FORT COLLINS, CO 80526



No.	Revision	Date

Sheet Title:
SCHEDULES
DETAILS

Project
EC REST ROOMS
CONSTRUCTION SET
Date 03/02/2020
Sheet A301
Scale VARIES

GENERAL CONSTRUCTION NOTES

- THE ELECTRICAL CONTRACTOR SHALL VERIFY THAT ALL ELECTRICAL ITEMS TO REMAIN OR BE RELOCATED AND REUSED ARE IN WORKING ORDER PRIOR TO ANY DEMOLITION WORK. IF THE EXISTING MATERIAL IS FOUND TO BE INOPERABLE, CONTRACTOR SHALL INFORM THE OWNER. ONCE ANY DEMOLITION WORK HAS BEGUN, ANY INOPERABLE OR DAMAGED MATERIAL SHALL BE REPAIRED OR REPLACED AT THE CONTRACTOR'S EXPENSE.
- VERIFICATION OF EXISTING CONDITIONS. "IN AS MUCH AS THE REMODELING AND/OR REHABILITATION OF THE EXISTING BUILDING REQUIRES THAT CERTAIN ASSUMPTIONS BE MADE REGARDING EXISTING CONDITIONS, AND BECAUSE SOME OF THESE ASSUMPTIONS MAY NOT BE VERIFIABLE WITHOUT DESTROYING OTHERWISE ADEQUATE OR SERVICEABLE PORTIONS OF THE BUILDING, THE GENERAL CONTRACTOR AGREES THAT, EXCEPT FOR NEGLIGENCE ON THAT PART OF THE DESIGN PROFESSIONAL THE CONTRACTOR WILL HOLD HARMLESS, INDEMNIFY AND DEFEND THE DESIGN PROFESSIONAL FROM AND AGAINST ANY AND ALL CLAIMS ARISING OUT OF THE PROFESSIONAL SERVICES PROVIDED."
- ANY ELECTRICAL ITEMS SHOWN OR NOT SHOWN ON THE PLANS, OR WHERE CIRCUITS ARE REMOVED BY DEMOLITION, SHALL UPON COMPLETION OF REMODEL WORK BE LEFT IN WORKING CONDITION.
- ALL PHASES OF THE ELECTRICAL WORK SHALL BE COORDINATED WITH THE ARCHITECT. WORK SHALL BE DONE IN A FASHION TO CAUSE AS LITTLE INCONVENIENCE AS POSSIBLE TO THE OWNER.
- IT IS THE RESPONSIBILITY OF THE ELECTRICAL CONTRACTOR TO REVIEW ALL DRAWINGS FOR WORK UNDER THIS CONTRACT. NO EXTRAS WILL BE ALLOWED FOR WORK SHOWN ON MECHANICAL AND ARCHITECTURAL DRAWINGS.
- ELECTRICAL DEVICES NOTED TO BE REMOVED SHALL BE REMOVED BACK TO A POINT WHERE EXISTING CONDUIT CAN BE ABANDONED IN CONCEALED SPACES. REMOVE ALL WIRING FROM ABANDONED CONDUIT. ALL BOXES TO BE REMOVED SHALL BE TAKEN OUT OF WALLS AND HAVE HOLES REFINISHED TO MATCH WALL FINISH.
- ELECTRICAL CONTRACTOR SHALL NOT DEFACE ANY AREAS OF THE BUILDING WHERE REMODELING IS NOT BEING DONE.
- THE ELECTRICAL CONTRACTOR SHALL BE ON SITE DURING ALL ELECTRICAL INSPECTIONS. NO ADDITIONAL FEES OR OVERTIME WILL BE PAID FOR AFTER HOURS INSPECTIONS.
- RACEWAYS: ALL CONDUIT SHALL BE CONCEALED WHEREVER POSSIBLE. CONDUIT SHALL NOT BE EXPOSED IN FINISHED AREAS (EXCLUDES MECHANICAL ROOMS, STORAGE CLOSETS, AND SIMILAR AREAS). EXPOSED RACEWAYS SHALL BE SURFACE RACEWAYS PER SPECIFICATIONS.
- ROUTING OF EXISTING CONCEALED CONDUIT NOT KNOWN. LOCATION DETERMINED BY ELECTRICAL CONTRACTOR. ELECTRICAL CONTRACTOR SHALL RE-CIRCUIT AS NOTED UTILIZING ANY EXISTING CONDUIT. HE SHALL REMOVE EXISTING WIRE AND RE-PULL NEW. ALL NEW CONDUIT ADDED SHALL BE CONCEALED WHEREVER POSSIBLE.
- SURFACE RACEWAY: WHEREVER CONCEALED CONDUIT IN FINISHED AREAS IS NOT POSSIBLE, ELECTRICAL CONTRACTOR SHALL INSTALL SURFACE MOUNTED RACEWAYS EQUAL TO WIREMOLD. RUN SURFACE RACEWAYS IN CORNER OF WALL AND CEILING. ALL RACEWAYS THAT ARE EXPOSED SHALL BE APPROVED BY ARCHITECT PRIOR TO ROUGH-IN.
- TERMINATING AND SPLICING: MAKE ALL JOINTS AND SPLICES IN BRANCH CIRCUIT WIRING WITH APPROVED SOLDERLESS TOOL APPLIED OR TWIST-ON CONNECTORS, IN THE VARIOUS BOXES, GUTTERS, AND SIMILAR LOCATIONS, BUT NOT IN RACEWAYS. LEAVE SUFFICIENT SLACK TO PERMIT TWO (2) OR MORE SPLICES OR JOINTS TO BE REMADE IN CASE OF FAULT.
- NM (ROMEX CABLE) WILL NOT BE ALLOWED ON THIS PROJECT.
- ELECTRICAL CONTRACTOR SHALL RECEIVE, FROM SYSTEM SUPPLIERS, ALL WIRING DIAGRAMS FOR ALL EQUIPMENT, PRIOR TO ANY ROUGH-IN, TO ASSURE PROPER ELECTRICAL CHARACTERISTICS ARE PROVIDED. ELECTRICAL CONTRACTOR SHALL PROVIDE ARCHITECT WRITTEN NOTIFICATION PRIOR TO ROUGH-IN, THAT ALL WIRING DIAGRAMS HAVE BEEN RECEIVED AND REVIEWED FOR CORRECTNESS. ANY INCORRECT WIRING OR DEVICES INSTALLED BY ELECTRICAL CONTRACTOR WITHOUT WIRING DIAGRAMS SHALL BE CORRECTED AT ELECTRICAL CONTRACTOR'S EXPENSE.
- ELECTRICAL CONTRACTOR SHALL RECEIVE, FROM MECHANICAL CONTRACTOR, ALL WIRING DIAGRAMS AND SHOP DRAWINGS FOR ALL MECHANICAL EQUIPMENT, PRIOR TO ANY ROUGH-IN, TO ASSURE PROPER ELECTRICAL CHARACTERISTICS, VOLTAGE, PHASE, HORSEPOWER, AMPERE, KILOWATTS AND ETC. ARE PROVIDED. ELECTRICAL CONTRACTOR SHALL PROVIDE ARCHITECT WRITTEN NOTIFICATION PRIOR TO ANY ROUGH-IN, THAT ALL WIRING DIAGRAMS AND SHOP DRAWINGS HAVE BEEN RECEIVED AND REVIEWED FOR CORRECTNESS. ANY INCORRECT WIRING OR DEVICES INSTALLED BY ELECTRICAL CONTRACTOR WITHOUT WIRING DIAGRAMS SHALL BE CORRECTED AT ELECTRICAL CONTRACTOR'S EXPENSE.
- COORDINATE WITH MECHANICAL CONTRACTOR LOCATION AND INSTALLATION OF ANY ELECTRICAL CONTROLS FOR MECHANICAL UNITS AND PROVIDE 120V CIRCUIT AS REQUIRED.
- ALL EXISTING AND NEW SMOKE DETECTORS IN OR NEAR AREAS BEING REMODELED SHALL BE BAGGED OR REMOVED. IF REMOVED, STORE IN A SEALED BAG UNTIL ALL REMODELING WORK IS COMPLETE. IF SMOKE DETECTORS ARE NOT BAGGED OR REMOVED THEY SHALL BE REPLACED WITH NEW DETECTORS AT CONTRACTOR'S EXPENSE WHEN THE PROJECT IS COMPLETED.
- EXACT ELECTRICAL DEMOLITION REQUIREMENTS NOT SHOWN ON THE DRAWINGS. ELECTRICAL CONTRACTOR SHALL VISIT THE SITE PRIOR TO BIDDING TO DETERMINE EXACT DEMOLITION WORK TO BE DONE AND SHALL INCLUDE ALL DEMOLITION COSTS IN THEIR BID.
- ELECTRICAL CONTRACTOR SHALL VERIFY ELECTRICAL DEVICE LOCATIONS IN ALL CASEWORK WITH ARCHITECTURAL CASEWORK DETAILS PRIOR TO ANY ROUGH-IN.
- THE CONTRACTOR SHALL COORDINATE ALL ELECTRICAL DEVICE LOCATIONS WITH THE ARCHITECTURAL PLANS, ELEVATIONS, AND DIAGRAMS.

- ELECTRICAL CONTRACTOR SHALL VERIFY FINAL LOCATIONS OF ALL SINKS WITH PLUMBING CONTRACTOR PRIOR TO ROUGH-IN. ANY ELECTRICAL DEVICES LOCATED ABOVE COUNTER AND BEHIND FINAL SINK LOCATIONS SHALL BE SHIFTED A MINIMUM OF 6" TO EITHER SIDE OF SINK. ANY ELECTRICAL DEVICES LEFT BEHIND SINK AT TIME OF FINAL ELECTRICAL OBSERVATION SHALL BE RELOCATED AT ELECTRICAL CONTRACTOR'S EXPENSE.
- BACK TO BACK RECEPTACLES ARE NOT PERMITTED. MAINTAIN SEPARATION OF AT LEAST ONE STUD - REFER TO ARCHITECTURAL ACOUSTICAL DETAILS. IF BOXES ARE WITHIN 24" OF EACH OTHER IN A FIRE RATED WALL A FIRE BARRIER MOLDABLE PUTTY (3M OR EQUIVALENT) SHALL BE USED.
- FEED THROUGH GFCI PROTECTION OF RECEPTACLES IS ACCEPTABLE ONLY WHERE RECEPTACLES ARE IN SAME ROOM AND DRAWINGS DO NOT INDICATE OTHERWISE.
- PROVIDE BLANK COVER PLATES AND INSTALL THEM ON ALL UNUSED ROUGH-INS.
- INSTALL PIGTAIL AT ALL RECEPTACLES FOR FINAL CONNECTIONS.
- ALL NEW ELECTRICAL ITEMS SHOWN ON EXISTING WALLS AND CEILINGS SHALL BE FLUSH MOUNTED UNLESS NOTED OTHERWISE. CUT AND PATCH EXISTING WALLS AND CEILINGS TO CONCEAL ALL MOUNTING BOXES AND CONDUITS.
- ELECTRICAL CONTRACTOR SHALL COORDINATE WITH GC TO MAINTAIN FIRE RATINGS FOR ALL CONDUIT PENETRATIONS, INCLUDING CONDUIT SLEEVES, THROUGH FIRE RATED CONSTRUCTION. THIS INCLUDES SEALING ALL SPARE CONDUITS (SPECIAL SYSTEMS, ETC.).
- IT IS THE CONTRACTOR'S RESPONSIBILITY TO MEASURE THE HORIZONTAL AND VERTICAL DIMENSIONS OF HIS WORK BEFORE INSTALLATION AND COORDINATE THESE DIMENSIONS WITH OTHER CONTRACTORS IMMEDIATELY. IF CEILING HEIGHTS ARE AFFECTED, NOTIFY THE OTHER CONTRACTORS AND THE ARCHITECT IMMEDIATELY. FAILURE TO DO SO WILL RESULT IN REJECTION OF INSTALLED WORK AND REINSTALLATION OF PROPERLY LOCATED AND COORDINATED WORK WILL BE AT THIS CONTRACTOR'S EXPENSE.
- LIGHT FIXTURES AND DEVICES IN 1-HOUR FIRE RATED CEILINGS MUST BE 'TENTED'. TENTING WILL BE PERFORMED BY OTHERS (EC TO COORDINATE WITH GC). COORDINATE HEIGHT REQUIRED FOR ADDITIONAL TENTING WITH CEILING AND MECHANICAL CONTRACTORS. REFER TO ARCHITECTURAL DRAWINGS.
- FIXTURE WHIPS SHALL BE SUPPORTED ABOVE ACCESSIBLE CEILING. LAYING FIXTURE WHIPS ON TOP OF THE GRID OR SUPPORTING USING THE FIXTURE HANGERS IS NOT ALLOWED. FIXTURE WHIPS SHALL NOT CONTACT PLUMBING.
- RELOCATIONS: OWNER RESERVES THE RIGHT TO RELOCATE ANY ELECTRICAL DEVICE, UP TO A DISTANCE OF 12'-0", BEFORE INSTALLATION WITHOUT EXTRA CHARGE FROM ELECTRICAL CONTRACTOR.
- ELECTRICAL DRAWINGS ARE DIAGRAMMATIC ONLY. EXACT LOCATION OF ALL SYSTEMS AND EQUIPMENT SHALL BE FIELD VERIFIED AND COORDINATED WITH OTHER TRADES PRIOR TO ANY INSTALLATION. WHERE EXACT LOCATIONS ARE NECESSARY, THEY ARE DIMENSIONED ON THESE DRAWINGS. WHERE THERE IS A QUESTION OF ADEQUATE CLEARANCE OR COORDINATION BETWEEN TRADES, THIS CONTRACTOR SHALL PREPARE SHOP DRAWINGS FOR ENGINEER'S REVIEW. ON ALL SPECIAL SYSTEMS REQUIRING DRAWINGS BY LICENSED INSTALLATION CONTRACTORS, SUCH AS FIRE PROTECTION, SUCH DRAWINGS SHALL BE SUBMITTED WITHIN 30 DAYS AFTER AWARD OF CONTRACT.
- EMT CONDUIT FITTINGS: DRY LOCATIONS ALL EMT COUPLERS AND CONNECTORS SHALL BE STEEL SET SCREW TYPE. DIE CAST FITTINGS SHALL NOT BE USED ON THIS PROJECT. DAMP/WET LOCATIONS, USE STEEL COMPRESSION GLAND TYPE COUPLER AND CONNECTORS.
- ALL WIRING INCLUDING SPECIAL SYSTEMS/LOW VOLTAGE THAT IS IN AN EXPOSED CEILING AREA SHALL BE IN CONDUIT. ALL SPLICES SHALL BE IN J-BOXES.
- ACCESS PANELS REQUIRED BY THE ELECTRICAL CONTRACTOR SHALL BE PROVIDED BY THE ELECTRICAL BID CONTRACTOR, THEN TURNED OVER TO THE APPROPRIATE TRADE FOR INSTALLATION. SEE ARCHITECTURAL SPECIFICATION.
- ELECTRICAL CONTRACTOR IS RESPONSIBLE TO COORDINATE WITH THE GENERAL CONTRACTOR TO OBTAIN ACTUAL ROOM NAMES AND NUMBERS, DESIGNATED BY THE OWNER/ARCHITECT AT THE COMPLETION OF THE PROJECT. ACTUAL ROOM NAMES AND NUMBERS SHALL BE USED ON ALL PANEL SCHEDULES, COMPUTER PROGRAMMING, GRAPHIC PLAQUES, SOUND SYSTEMS, TELEPHONE SYSTEM, INTERCOMS, FIRE ALARMS, SECURITY SYSTEMS, CATV SYSTEMS, AND SIMILAR.
- CONTRACTOR SHALL NOT FASTEN, ATTACH OR HANG ANY MATERIAL FROM THE ROOF DECK. ALL CONDUITS, JUNCTION BOXES, FIXTURES, DEVICES AND EQUIPMENT SHALL BE HUNG FROM THE STRUCTURAL STEEL FRAME AND SHALL BE PLACED WITH A MINIMUM CLEARANCE PER 2017 NEC BELOW THE ROOF DECK. WIRING AND CONDUITS SHALL NOT BE PLACED WITHIN THE RIBS OF THE ROOF DECK. CONTRACTOR SHALL NOT LOOSEN, REMOVE OR CUT ANY ROOFING SYSTEM FASTENERS PROTRUDING THROUGH THE ROOF DECK.
- ALL ELECTRICAL DEVICES, CONDUIT, J-BOXES, CABLE SUPPORTS, ETC. THAT ARE REQUIRED TO BE SUPPORTED ABOVE THE GRID CEILINGS SHALL BE SUPPORTED FROM THE STRUCTURE VIA THREADED RODS, ALL AREAS.
- MULTI-WIRE BRANCH CIRCUITS ARE NOT PERMITTED U.O.N. ON DRAWINGS. WHERE THEY ARE INSTALLED THEY SHALL BE COMMON TRIP OR HAVE HANDLE TIES AS REQUIRED BY 2017 N.E.C.
- SWITCHES AND RECEPTACLES SHALL BE IDENTIFIED AS TO PANEL AND CIRCUIT BREAKER FED FROM. LABEL COVERPLATE ON FRONT PER SPECIFICATION AND ON BACK WITH PERMANENT INK ENSURE NO BLEED THROUGH.
- THESE DRAWINGS ARE SUBJECT TO AN APPROVAL OF THE BUILDING DEPARTMENT, FIRE MARSHAL, UTILITY COMPANY, AND OTHER AGENCIES AUTHORITY HAVING JURISDICTION (AHJ). BY THE ACT OF SUBMITTING A BID PROPOSAL FOR WORK, THE CONTRACTOR HAS REVIEWED THE PLANS THOROUGHLY AND ACCEPTS FULL RESPONSIBILITY OF PLAN CORRECTIONS AND ASSOCIATED CONSTRUCTION COSTS REQUIRED BY AHJ.
- SEE ARCHITECTURAL REFLECTED CEILING PLAN FOR EXACT LOCATION OF LIGHT FIXTURES.
- FIRE ALARM IS DESIGN BUILT BY CONTRACTOR, PROVIDE COLORADO PE STAMPED FIRE ALARM DRAWINGS ACCORDINGLY.

ELECTRICAL ABBREVIATIONS

AC	ABOVE COUNTER	MC	MECHANICAL CONTRACTOR
AFF	ABOVE FINISHED FLOOR	MCB	MAIN CIRCUIT BREAKER
AFG	ABOVE FINISHED GRADE	MDP	MAIN DISTRIBUTION PANEL
AIC	AMP. INTERRUPTING CAPACITY	MECH	MECHANICAL
AL	ALUMINUM	MLO	MAIN LUG ONLY
ANN	ANNUNCIATOR	MTD	MOUNTED
ARCH	ARCHITECT	(N)	NEW
BFG	BELOW FINISHED GRADE	NF	NON FUSED
BKR	BREAKER	N.T.S.	NOT TO SCALE
BTM	BOTTOM	NL	NIGHT LIGHT
BWE	BAKED WHITE ENAMEL	PB	PUSH BUTTON
C	CONDUIT	PC	PHOTO CELL
CASA	COLOR AS SELECTED BY ARCHITECT	PH	PHASE
CATV	CABLE TELEVISION	PNL	PANEL
CKT	CIRCUIT	PT	POTENTIAL TRANSFORMER
CLG	CEILING	PWR	POWER
CT	CURRENT TRANSFORMER	RECEPT, RCPT, REC	RECEPTACLE
CU	COPPER	RL	RELOCATE
DISC	DISCONNECT	DOWN	DOWN
DN	DOWN	RT	RAIN TIGHT, NEMA 3R
DPDT	DOUBLE POLE DOUBLE THROW	SCA	SHORT CIRCUIT AVAILABLE
DPST	DOUBLE POLE SINGLE THROW	SPC	SPACE
EC	ELECTRICAL CONTRACTOR	SPD	SURGE PROTECTION DEVICE
ELEC	ELECTRICAL	SPDT	SINGLE POLE DOUBLE THROW
EM	EMERGENCY	SPST	SINGLE POLE SINGLE THROW
EMT	ELECTRICAL METALLIC TUBING	SPR	SPARE
EWC	ELECTRICAL WATER COOLER	SSL	SOLID-STATE LIGHTING
EXIST, EX. (E)	EXISTING	SW	SWITCH
F.	FUSED	T-STAT	THERMOSTAT
FLR	FLOOR	TBD	TO BE DETERMINED
TC	TIME CLOCK	TTB	TELEPHONE TERMINAL BACKBOARD
FLUOR	FLUORESCENT	TYP	TYPICAL
GC	GENERAL CONTRACTOR	U.O.N.	UNLESS OTHERWISE NOTED
GFI	GROUND FAULT INTERRUPTER	UC	UNDER COUNTER
GRC	GALVANIZED RIGID CONDUIT	V	VOLTS
GRD	GROUND	VA	VOLT-AMPERES
HOA	HAND-OFF-AUTO	VAC	VOLTS-ALTERNATING CURRENT
HT	HEAT TRACE	VFD	VARIABLE FREQUENCY DRIVE
IG	ISOLATED GROUND	W	WATTS
J-BOX	JUNCTION BOX	W/	WITH
LED	LIGHT-EMITTING DIODE	W/O	WITHOUT
LOC	LOCATION	WG	WIRE GUARD
LTG	LIGHTING	WP	WEATHERPROOF
LTF	LIQUID TIGHT FLEXIBLE CONDUIT	XFMR	TRANSFORMER
LTS	LIGHTS		

NOTE: THIS IS A COMPREHENSIVE LEGEND AND ABBREVIATIONS LIST AND ALL SYMBOLS SHOWN MAY NOT APPEAR ON DRAWINGS.

ELECTRICAL DRAWING INDEX

E001	GENERAL CONSTRUCTION NOTES AND LEGEND
ED101	ELECTRICAL DEMO PLANS
E101	ELECTRICAL PLAN
E201	ELECTRICAL SPECIFICATIONS

ELECTRICAL LEGEND

	FLAG NOTE	\$	NOTE: ALL SWITCHES SHALL BE MOUNTED AT 48" AFF TO TOP OF BOX (U.O.N.)
	MECHANICAL EQUIPMENT SYMBOL	\$	SINGLE POLE SWITCH, 20 AMP U.O.N.
	SPECIAL EQUIPMENT SYMBOL	\$2	DOUBLE POLE SWITCH, 20 AMP U.O.N.
	INDICATES AIMING DIRECTION	\$3	3 - WAY SWITCH, 20 AMP U.O.N.
	INDICATES EXISTING DEVICE TO REMAIN	\$30	SINGLE POLE SWITCH, 20 AMP U.O.N. 3 - THREE WAY, a - SWITCHING
	INDICATES EXISTING DEVICE TO BE REMOVED	\$4	4 - WAY SWITCH, 20 AMP U.O.N.
	EXISTING CIRCUIT RUN TO REMAIN	\$K	KEYED SWITCH, 20 AMP U.O.N.
	EXISTING CIRCUIT RUN TO BE REMOVED	\$P	PILOT SWITCH, 20 AMP U.O.N. SWITCH ON, LIGHT ON
	CIRCUIT RUN: EXPOSED	\$TO	SWITCH WITH THERMAL OVERLOAD, 20 AMP U.O.N.
	CIRCUIT RUN: UNDERFLOOR	\$TS	DIGITAL TIMER SWITCH
	CIRCUIT RUN: UNDERGROUND	\$VS	SWITCH VARIABLE SPEED
	CIRCUIT RUN: WALLS OR CEILING	\$LV	SWITCH LOW VOLTAGE
	CIRCUIT TURNS UP	\$D	DIMMER SWITCH AS NOTED, 20 AMP U.O.N.
	CIRCUIT TURNS DOWN	\$P	COMBINATION SWITCH/RECEPTACLE
	UNDERGROUND TELEPHONE RUN	\$P	SINGLE RECEPTACLE, + 16" AFF TO BOTTOM OF BOX (U.O.N.)
	UNDERGROUND SECONDARY OR PRIMARY SERVICE	\$P	DUPLEX RECEPTACLE, + 16" AFF TO BOTTOM OF BOX (U.O.N.)
	GROUND BUS	\$P	DUPLEX RECEPTACLE, SPLIT WIRED
	SURFACE RACEWAY	\$P	DUPLEX RECEPTACLE, INDIVIDUAL GROUND FAULT RECEPTACLE
	PLUG STRIP AS NOTED	\$P	DOUBLE DUPLEX RECEPTACLE, + 16" AFF TO BOTTOM OF BOX (U.O.N.)
	LOW VOLTAGE CIRCUIT	\$P	DUPLEX RECEPTACLE, SPLIT WIRED
	MOISTURE OR EXPLOSION PROOF SEAL	\$P	TELEPHONE OUTLET, + 16" AFF TO BOTTOM OF BOX (U.O.N.) W - WALL OUTLET, + 54" AFF (U.O.N.) P - PAYPHONE, + 40" AFF (U.O.N.) X DENOTES # OF JACKS
	HOME RUN (PROVIDE DEDICATED NEUTRALS MULTI-WIRE BRANCH CIRCUITS NOT ALLOWED)	\$P	DATA OUTLET, + 16" AFF TO BOTTOM OF BOX (U.O.N.) X DENOTES # OF JACKS
	A - PANEL DESIGNATION 1,3,5 - CIRCUIT NUMBER, 6 CONDUCTORS U.O.N.	\$P	DATA/VOICE OUTLET, + 16" AFF TO BOTTOM OF BOX (U.O.N.) SPECIAL PURPOSE OUTLET AS NOTED, + 16" AFF TO BOTTOM OF BOX (U.O.N.)
	TRANSFORMER	\$P	FLUSH FLOOR TELEPHONE OUTLET S - SURFACE PEDESTAL
	WEATHERHEAD	\$P	FLUSH FLOOR DUPLEX OUTLET S - SURFACE PEDESTAL
	MAIN DISTRIBUTION PANEL	\$P	MULTI-CELL FLOOR BOX
	SWITCH AND FUSE	\$P	J-BOX: CEILING
	CIRCUIT BREAKER	\$P	J-BOX: WALL
	CT'S	\$P	EMERGENCY POWER OFF (MUSHROOM HEAD)
	PT'S	\$P	MOTOR OUTLET AND CONNECTION
	GROUND	\$P	MAGNETIC STARTER OR CONTACTOR
	METER	\$P	DISCONNECT SWITCH
	ELECTRICAL PANEL	\$P	DISCONNECT SWITCH NF - NON-FUSED
	TELEPHONE TERMINAL BOARD	\$P	FIRE-SMOKE DAMPER/SMOKE DAMPER
	CONTACT - NORMALLY CLOSED (NC)	\$P	LIGHTING CONTROL STATION
	CONTACT - NORMALLY OPEN (NO)	\$P	OCCUPANCY SENSOR
	LIGHTING OUTLET: CEILING RECESSED	\$P	VACANCY SENSOR
	LIGHTING OUTLET: CEILING SURFACE	\$P	PHOTO CELL - ELECTRIC
	LIGHTING OUTLET: WALL MOUNTED	\$P	CONTACTOR
	SPOT LIGHT	\$P	RELAY
	PORCELAIN KEYLESS P&S110 W/ 150W A21 LAMP - pc (PULL CHAIN)		
	FLUORESCENT/LED FIXTURE: SURFACE		
	FLUORESCENT/LED FIXTURE: SUSPENDED DIRECT/INDIRECT		
	FLUORESCENT/LED FIXTURE: RECESSED IN DRYWALL		
	FLUORESCENT/LED FIXTURE: RECESSED IN GRID DIRECT/INDIRECT		
	FLUORESCENT/LED FIXTURE: RECESSED IN GRID PARABOLIC (U.O.N.)		
	FLUORESCENT/LED FIXTURE: WALL MOUNTED		
	FLUORESCENT/LED STRIP		
	TRACK LIGHTING FIXTURE		
	INDICATES NIGHT LIGHT OR EMERGENCY CIRCUIT		
	EXIT SIGN: CEILING MOUNTED		
	EXIT SIGN: WALL MOUNTED		
	EMERGENCY BATTERY WITH NO LAMPS(HEADS)		
	EMERGENCY BATTERY WITH LAMPS		
	REMOTE EMERGENCY LIGHTS		
	REMOTE INDICATING LIGHT		



POUDRE SCHOOL DISTRICT
ORLANDER ELEMENTARY SCHOOL
5401 AUNTIE STONE STREET
FORT COLLINS, CO 80526



No.	Revision	Date

Sheet Title:
GENERAL CONSTRUCTION NOTES AND LEGEND

Project EC REST ROOMS	
CONSTRUCTION SET	
Date 03/02/2020	Sheet E001
Scale	



LOAD SUMMARY - LOAD REMOVED			
EXISTING LOAD REMOVED	QTY	LOAD	TOTAL
LIGHTING 2 LAMP SURFACE WRAP	2	65 W	130 WATTS
TOTAL LOAD REMOVED			130 WATTS

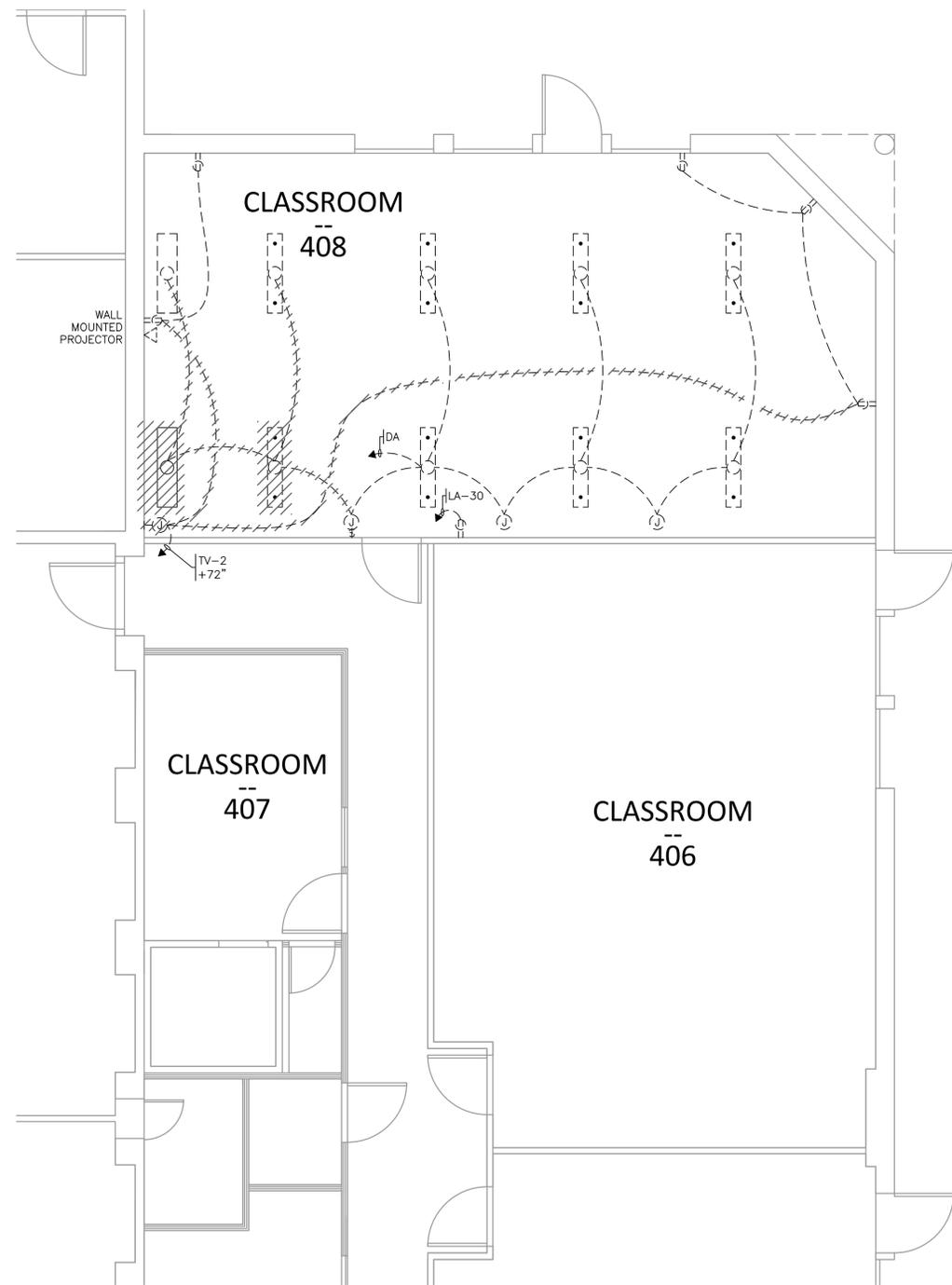

ENLARGED RESTROOM ELECTRICAL DEMO PLAN
 Scale: 1/4"=1'-0"
 NORTH

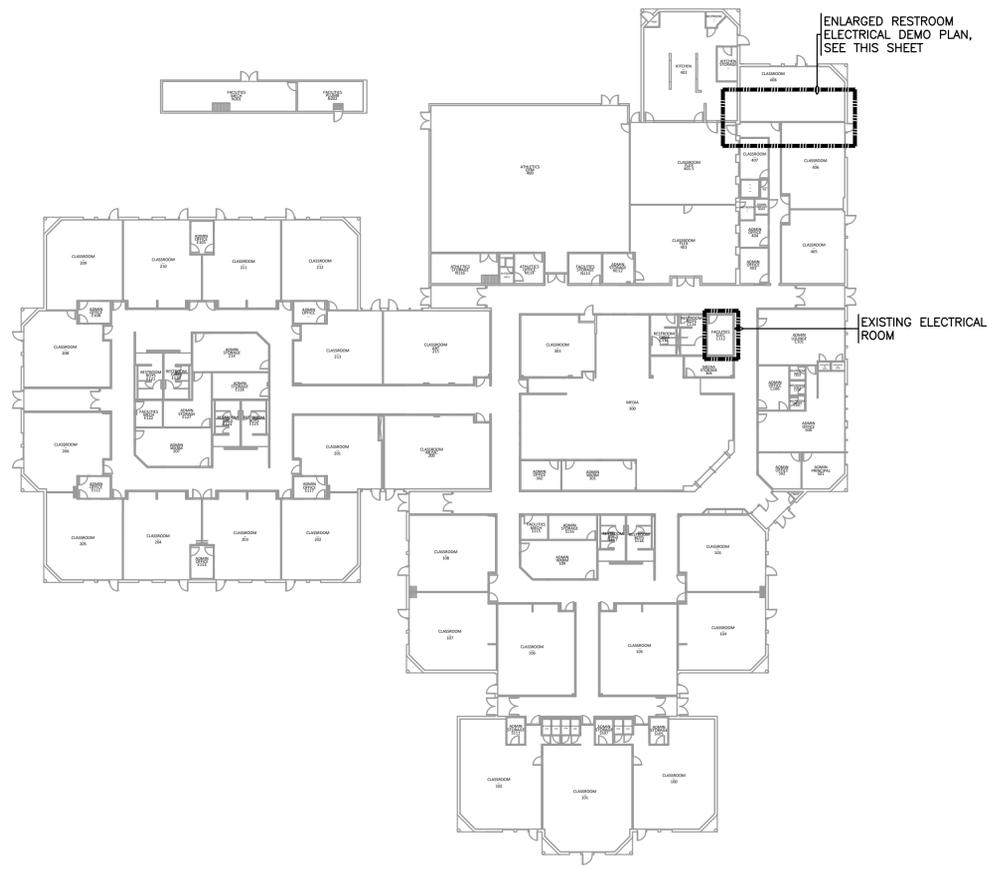

OVERALL PLAN
 Scale: 1"=30"
 NORTH



POUDRE SCHOOL DISTRICT
 ORLANDER ELEMENTARY SCHOOL
 5401 AUNTIE STONE STREET
 FORT COLLINS, CO 80526



No.	Revision	Date

Sheet Title:
 ELECTRICAL DEMO PLANS

Project EC REST ROOMS	
CONSTRUCTION SET	
Date 03/02/2020	Sheet ED101
Scale	



LOAD SUMMARY - Orlander ES	
MAX DEMAND PER XCEL @125% PER NEC	84.00 kW
	105.00 kW
LOAD ADDED THIS PROJECT	0.120 kW
LOAD REMOVED THIS PROJECT	0.130 kW
NEW TOTAL LOAD	104.99 kW
@ 90% POWER FACTOR	116.66 kVA
@ 208V 3PH	324 AMPS

LOAD SUMMARY - LOAD ADDED	
NEW LOAD ADDED	
LIGHTING	
TYPE 'A'	29 WATTS
TYPE 'B'	14 WATTS
TOTAL	43 WATTS
EXHAUST FAN	12 WATTS
CIRCULATION PUMP	65 WATTS
TOTAL LOAD ADDED	120 WATTS

FLAG NOTES - THIS SHEET ONLY	
1	EXHAUST FAN, 120V, 12W. COORDINATE CONTROLS WITH MECHANICAL.
2	CIRCULATION PUMP, 1/35 HP, 120V, 0.54A. COORDINATE CONTROLS WITH MECHANICAL. CIRCUIT VIA EXISTING GAS WATER HEATER CIRCUIT.
3	RE-CIRCUIT EXISTING LIGHTING TO REMAIN TO EXISTING LOCAL LIGHTING CIRCUIT.

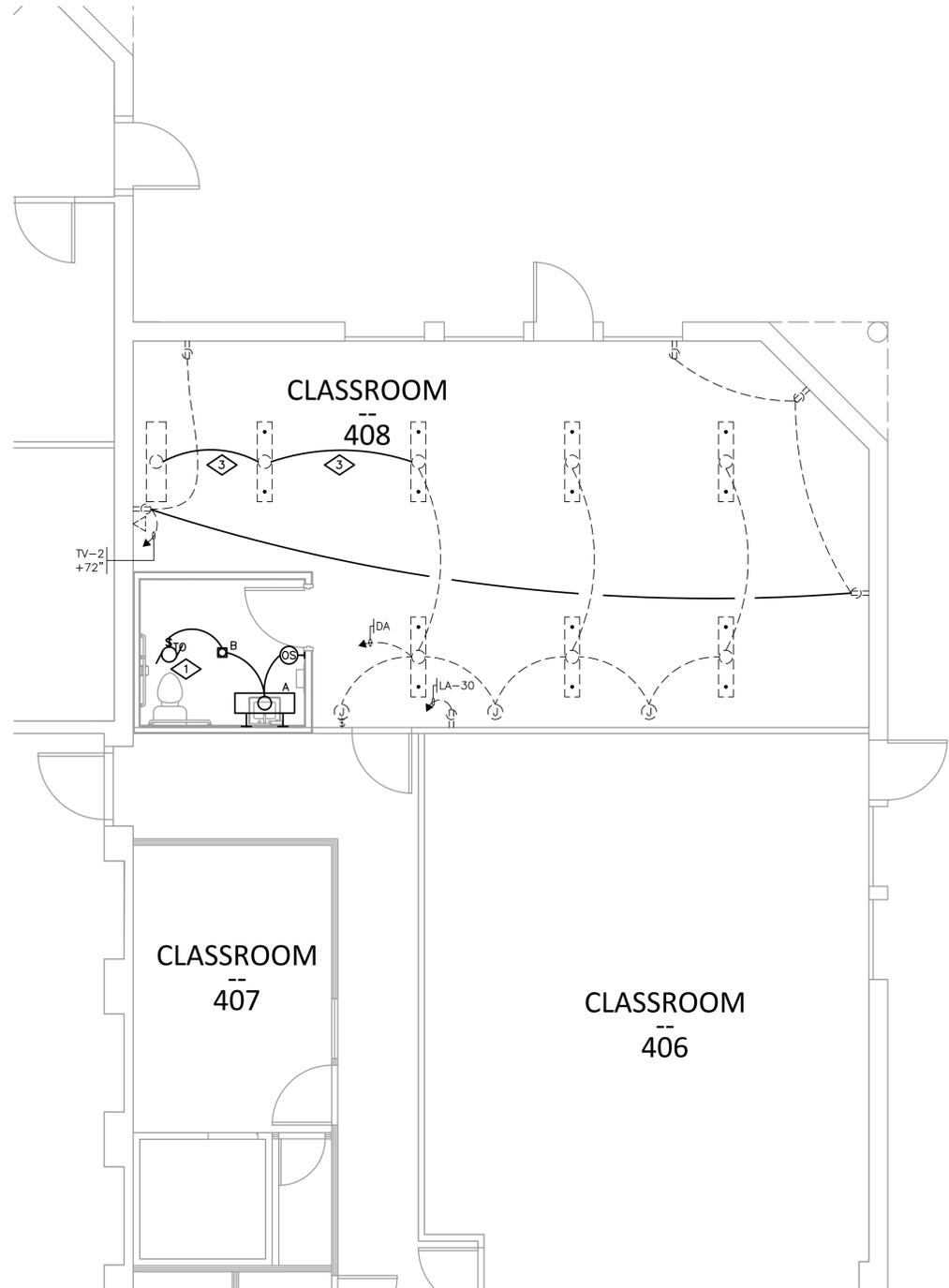

ENLARGED RESTROOM ELECTRICAL PLAN

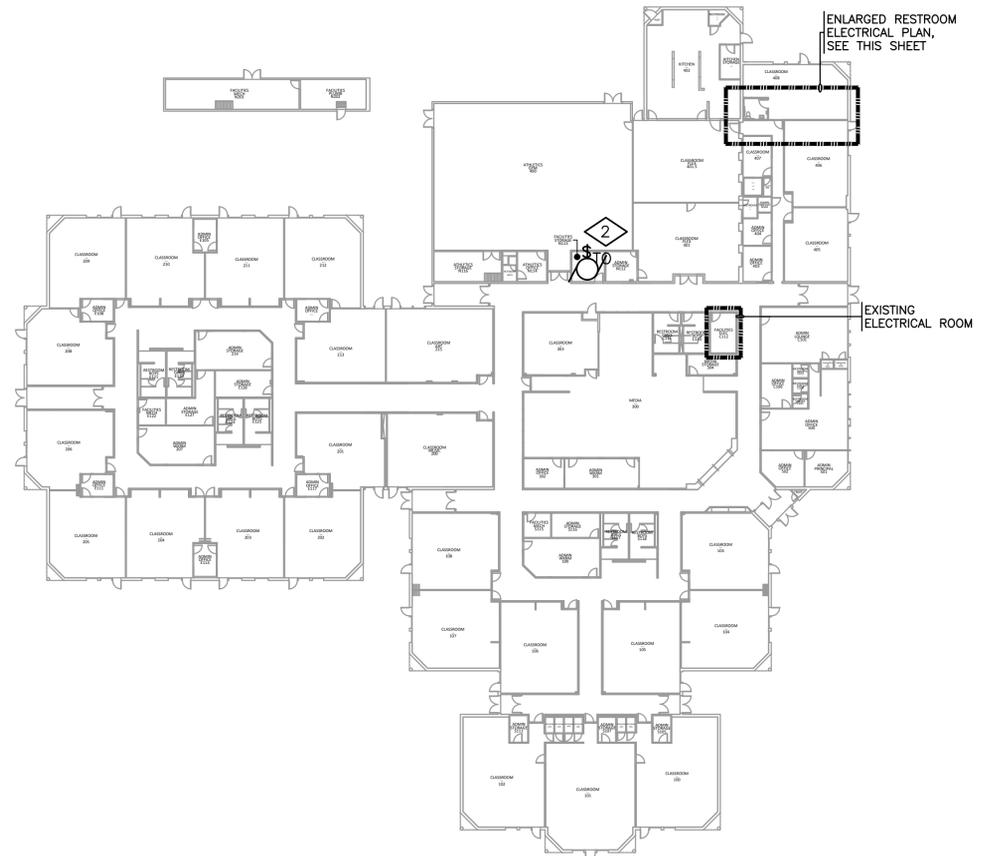

OVERALL PLAN



POUDRE SCHOOL DISTRICT
 ORLANDER ELEMENTARY SCHOOL
 5401 AUNTIE STONE STREET
 FORT COLLINS, CO 80526



No.	Revision	Date

Sheet Title:

ELECTRICAL PLANS

Project
 EC REST ROOMS

CONSTRUCTION SET

Date
 03/02/2020

Scale
 E101



RMC Nutt & Associates, LLC
 ELECTRICAL ENGINEERS
 4640 N. 187th ST., SUITE 2000
 ORELEVY, COLORADO 80524
 ORELEVY (970) 335-3388

Electrical Specifications

SECTION 16010 - GENERAL PROVISIONS

PART 1 - GENERAL

1.1 CONDITIONS:

- A. All work under this Section shall be governed by project general conditions, along with all supplements and amendments thereto, as published by Owner.
B. Comply with all applicable state and local codes, regulations and ordinances, and the latest applicable requirements of the National Electrical Code (NEC) of the NFPA, as interpreted by the local inspection authority that shall have final jurisdiction.
C. Comply also with all OSHA requirements and directives.
EXAMINATION OF PREMISES:
A. Examine the premises prior to bidding and become fully familiar with existing conditions.
PERMITS:
A. Secure and pay for all permits, fees, taxes, licenses and inspections in connection with the electrical work.
DRAWINGS AND SPECIFICATIONS:
A. Drawings are diagrammatic and indicate general arrangement of electrical work. Locations are approximate and shall be subject to minor modifications as directed by Engineer.
B. Contractor shall be responsible for exact fitting of all materials, equipment, etc., in building. All dimensions shall be verified on the job.
C. Refer to Architectural, Structural, and Mechanical Drawings and Specifications, as part of this set, and be responsible for all information contained therein as affects the electrical work.
D. Instructions such as "provide..." shall mean "Contractor shall be responsible for the furnishing and installing of new..." complete in every respect."

PART 2 - PRODUCTS

2.1 STANDARDS:

- A. All material shall be new and shall be listed by Underwriters Laboratories Incorporated (UL listed) for the purpose intended and shall bear the UL label. Damaged or defective materials shall be replaced. All materials shall comply with the latest NEMA standards.

PART 3 - EXECUTION

3.1 SHOP DRAWINGS:

- A. Furnish electronic (pdf) sets of Shop Drawings to Architect for the following:
1. Control Equipment.
2. Distribution Equipment.
3. Light Fixtures
B. All materials and equipment shall be approved prior to beginning work.
C. Receipt within 30 days after award of contract.
D. Shop Drawings, including:
1. Catalog data specifically for equipment to be used.
2. See shop drawing requirements in General Provisions.
E. Electrical Contractor shall provide shop drawing approval stamps on all equipment supplied by them prior to Engineer's shop drawing approval. The Electrical Contractor to check for conformance with the design of the project and compliance with the information given in the contract documents. Contractor is responsible for dimensions which shall be confirmed and correlated at the job site; fabrication process and techniques of construction.
3.2 RECORD DRAWINGS:
A. Maintain a complete set of Electrical Drawings at the job site with all changes in the work marked thereon in a contrasting color.
B. Electrical Contractor shall provide architect at completion of project a complete set of as-built drawings showing all changes in work marked there on including all system wiring diagrams.

3.3 COORDINATION:

- A. Order the progress of the work so as to conform to the progress of other trades. Coordinate all electrical installations and rough-ins as required.
3.4 WORKMANSHIP:
A. Provide a competent foreman on the job at all times. All work shall be accomplished in a manner which is neat, workmanlike, of first quality, and compatible with good commercial practices and standards. Provide competent workmen who are skilled as electricians.

3.5 INSTALLATION:

- A. Install all equipment and materials in accordance with information as indicated on drawings and in full accord with Manufacturer's recommendations.
3.6 CUTTING AND PATCHING:
A. Provide all cutting, channeling, chasing, drilling, etc., operations as may be required for electrical work. In general, all such operations shall be held to a minimum.
B. All patching and painting shall be done by Contractor.

3.7 CONSTRUCTION POWER AND LIGHTING:

- A. Provide construction power and lighting for construction as required. Energy costs will be paid by Owner. All temporary facilities shall be properly grounded, shall comply with NEC and OSHA requirements, and shall have ground fault protection.
3.8 SECONDARY SERVICE:
A. Power for distribution within the building is available from the secondary side of a pad mount transformer supplied by the local power company. This service shall be 3 phase, 4 wire, 120/208 volt, 60 Hertz alternating current for normal power and lighting requirements. General arrangement of the service equipment is shown on drawings. Equipment shall be as specified herein.

3.9 REMODEL WORK:

- A. Electrical Contractor shall remove all wiring devices, light fixtures, etc., which are indicated to be removed. In general, symbols which are dashed indicate existing devices which are to remain. Symbols which are dashed and are crosshatched indicate devices which are to be removed. Devices which are to be removed may require reworking conduit and wiring in order to maintain service to other devices. If removed devices are on walls or ceilings which are to remain, blank coverplates are to be installed on outlet boxes.
B. Where remodeling interferes with circuits in areas which are otherwise undisturbed, circuits shall be reworked as required.
C. Existing devices and circuiting which are shown are indicated only for informational purposes. Electrical Contractor shall visit the site and shall verify conditions as they exist and shall remove, relocate and/or rework any electrical equipment or circuits affected (whether indicated or not) due to removal or reworking of existing walls, ceilings, etc. Electrical Contractor shall familiarize himself with all work to be done by other trades by studying Architectural, Structural, Mechanical and Plumbing Drawings.
D. Coordinate routing of all conduits with Mechanical and Plumbing Contractors in order to avoid conflicts with ducts, pipes, etc.
E. Lighting fixtures removed and reused shall be cleaned and reconditioned by Contractor prior to reinstallation. Provide new lamps, lens ballasts, etc., as required to restore fixtures to operational condition.
F. All equipment, fixtures, devices, etc., which are removed shall be delivered to Owner for disposition. All items which are removed and not wanted by Owner and which are not reused shall become the property of Electrical Contractor and shall be removed from site.
G. The cost of cutting and patching necessary for the installation or removal of electrical work shall be included in the Electrical Contract. Coordinate with General Contractor.
H. Electrical Contractor shall remove and replace lighting fixtures; rework, relocate and replace conduit and wiring and do other work required by the installation of new ductwork, piping, etc., above existing ceiling. Coordinate with other Contractors and verify the extent of the work.

3.10 GUARANTEE:

- A. Guarantee all materials, labor, workmanship and successful operation of all equipment installed under this contract for a period of one year from date of final acceptance. Repair or replace, at no expense to Owner, all defects which may arise during this time due to inferior or defective materials, equipment, or workmanship.

3.11 SUBSTITUTIONS:

- A. The intent of Specifications is to establish quality standards of materials and equipment installed. Specific items are identified by Manufacturer, trade name or catalog designation. Should Contractor propose to furnish materials and equipment other than those specified as permitted by "or approved equal" clauses, he or she shall submit a written request in duplicate, at least five calendar days prior to bidding date, for any or all substitutions. Request shall be accompanied with complete descriptive and technical data and all other information deemed necessary by Engineer for evaluation. Substitutions submitted for approval shall list items as specified with the alternate substitution.
B. Where substitutions alter the design, conduit, wiring or space requirements indicated on drawings, Contractor shall include items of cost for the revised design and construction.
C. Substitutions sent by fax machine will not be acceptable and will not be reviewed.

3.12 OUTAGES:

- A. Coordinate all electrical service outages with Owner and General Contractor. Plan all work so that duration of outage is kept to an absolute minimum. Provide temporary wiring as necessary and as required in order to maintain continuous service for Owner's operation where outage must be accomplished during a time when power is deemed necessary by Owner, or when outage is to be of an extended duration, maximum 6 hours. All outage time and scheduling of same shall be as approved by Owner and shall conform to Owner's schedules.

3.13 DELIVERY AND STORAGE OF MATERIALS:

- A. Make provisions for delivery and safe storage of all materials and make the required arrangements with other Contractors on the job for the introduction into the building of equipment too large to pass through finished openings.
B. Where materials are indicated to be furnished by others to Contractor for installation, these materials shall be checked and their delivery properly receipted. Assume full responsibility for the storage and safe keeping of said materials from time of delivery until final acceptance.

3.14 AVAILABLE TO OWNER:

- A. Electrical Contractor shall be available to Owner for additional hook up to lights, equipment, etc., on time and material.
END OF SECTION 16010

SECTION 16100 - BASIC MATERIALS AND METHODS

PART 1 - GENERAL

1.1 STANDARDS:

- A. All materials shall be new, shall be UL listed for the purpose intended, and shall bear the UL label. Damaged or defective materials shall be replaced. All materials shall comply with latest NEMA standards.

PART 2 - PRODUCTS

2.4 SAFETY SWITCHES:

- A. Provide fusable and non-fusable heavy duty type disconnect switches where shown and required. Switches shall be horsepower rated, quick make, and quick-break, by same manufacturer as panelboards.

2.7 FUSES:

- A. Provide sizes, classes and types of fuses as indicated for all fused safety switches. All fuses 0-600 amps shall have the Class "R" rejection feature. Verify actual load current of all motors prior to ordering fuses and provide fuses of sizes as recommended by Manufacturer. Generally, motor fuses shall be the dual element type and shall be set at 110 percent of full load amps, or 125 percent where required for heavy duty usage or high ambient temperatures. Fuses shall be the power voltage rating to match circuit characteristics in which installed. Fuses indicated on drawings are those of Bussmann Co., equal by Gould Shawmut or Littell Fuse.

2.8 SPARE FUSES:

- A. Provide three spare fuses of each size and type installed. Place in a metal cabinet adjacent to main distribution equipment. Cabinet shall be wall mounted, shall have a hinged door and latch, and shall be labeled "SPARE FUSES" on cover.

2.9 NAMEPLATES:

- A. Provide 1 x 3 inch laminated plastic nameplates (1/4 inch high white letters; black background for normal power equipment, red background for emergency power equipment) for all switches, panelboards, controllers, etc., in main distribution switchboards and sub-distribution panelboards. Nameplates shall be permanently attached to equipment with two screws. Provide blank nameplates for all spares.
B. Multiple Gang Light Switches: Provide engraved coverplates 1/8 inch lettering black filled on all switch plates two and more ganged. Lettering shall indicate area served.
C. Light switches/receptacles (all): Provide panel and circuit Kroy labels on front of coverplate and label with marker on inside panel cover and circuit also.
D. Label all mechanical equipment, safety switches, and starters, etc., with raised letter tape. Nameplates and labels shall indicate the general areas and types of electrical load served by each circuit.
E. Neatly label all Junction box coverplates as to their function. Use a permanent ink pen. Labeling shall be lights, smoke detector power, elevator control, fire alarm, receptacles, etc. Labeling shall be done on J-boxes that are above accessible ceiling and in storage rooms and maintenance areas, etc. Do not label J-boxes in public view.

2.10 NM-NONMETALLIC SHEATHED CABLE NOT ALLOWED ON THIS PROJECT:

2.11 CONDUCTORS:

- A. Provide a complete system of conductors for all raceway systems. All conductors shall be rated 600V, and shall be of a manufacturer subscribing to applicable IPECA and NEMA standards and practices. Conductors shall be of sizes and types as indicated, and as required by NEC for specific uses. Where quantities of conductors in a raceway system are not specifically indicated, provide number as required to maintain function, control and number of circuits as indicated. All conductors shall be UL listed and approved, and shall conform to the following:
1. Minimum wire size shall be #12 AWG copper except for control or signal circuits which may be #14 AWG copper.
2. Unless otherwise indicated, all wiring for branch circuits shall be copper #12 AWG in 1/2" conduit, protected by 20 ampere circuit breakers. See Voltage Drop.
3. Voltage Drop: If distance from panel to first outlet is 75 feet or greater (for 120V circuits), #10 shall be installed from circuit breaker to every device in circuit.
4. Wire sizes #10 AWG copper and smaller shall be solid; #8 AWG copper and larger shall be stranded.
5. The following insulation standards shall apply:
a. All feeder conductors shall be type THWN, XHHW or RHW.
b. Other conductors shall be per NEC THHN/THWN copper unless noted otherwise, Article 310.
c. Type THHN/THWN copper for exterior runs in conduit.
6. Motor wiring for power shall be stranded.
B. Aluminum conductors shall not be used on this project.
C. The use of AC (Armored Cable), NM Cable (Romex), or flexible conduit shall not be used for branch circuits or feeders. MC cable shall be allowed for final connection within rooms. Home runs shall be in EMT.

2.12 CONDUITS:

- A. Conduits shall be provided for all wiring runs as shown and specified. All sizes shall be per NEC. Use GRC where required by code, utility company, for mechanical protection and as shown. Type IMC may be used in lieu of GRC where permitted. Use EMT for all other runs. Provide approved couplings and connectors for all connections. Final connections to motors and other vibrating or rotating equipment shall be made in flexible conduit.
B. Heavywall, type II, rigid, Schedule 40 1 1/2"
1. For all wiring runs in or under the floor slab which is in contact with the ground.
2. For all wiring runs buried underground, unless otherwise indicated.
3. Do not use Schedule 40 or 80 PVC above ground. Conduit sizes 1" and smaller use schedule 80 PVC elbows and conduit sizes 1 1/4" and larger use GRC tar coated elbows to max. 6" above grade then change to EMT conduit. Note: Provide expansion joints in accordance with Manufacturer's recommendations.
C. Use approved type couplings and connectors in all conduit runs and make all joints tight. Provide insulated bushings for all terminations in pipe size 1 1/4" and larger. Provide all steel set screw couplings and connectors for all other conduits. Provide expansion fitting and bonding conductors for all runs which cross building expansion joints. Provide waterproof steel compression gland couplings and connections for all runs in wet locations such as exposed to weather, buried in slabs, etc.

2.13 SUPPORTS AND HANGERS:

- A. Provide supports and hangers as necessary and as required to insure a good and substantial installation. Support raceways, fixtures, cabinets, boxes, etc., on approved types of trapeze hangers and wall brackets as manufactured by Unistrut or acceptable equal. Provide steel hanger rods securely fastened to or through the building structure for all trapezes, etc. Do not suspend from mechanical piping or ductwork. Perforated plumber's straps or wire will not be permitted.
B. Obtain Architect's approval for the use of powder powered fasteners and use only in locations as he may direct.

2.14 OUTLETS:

- A. Outlets shall be galvanized steel or zinc pressed steel outlet boxes for all locations except where otherwise indicated or where cast metal boxes are required by NEC. Boxes are to be 4" square or octagonal, 2 1/8" Depth minimum. Provide plaster or tile rings for all flush outlets installed where wood, drywall, tile, plaster, etc., types of finishes are applied. All outlets for exterior application shall be cast, weatherproof type, with gasket and case coverplate. Tile boxes of extra depth may be used for exterior, dry applications where masonry block or brick walls constitute the finished wall surface. In any event, provide outlet boxes of proper type and design for the particular fixture or device to be installed. Boxes shall be as manufactured by Steel City or acceptable equal.
B. Surface mounted boxes shall be cast metal weatherproof, with grounding terminal, threaded hubs, and shall be similar and equal to Crouse-Hinds design Type FD or FS.
C. Pull Boxes: Provide pull boxes in raceway runs as required by NEC and job conditions. Install in accessible locations.
D. Surface Raceway: Surface raceway boxes same manufacturer as surface raceway.

2.15 LIGHTING EQUIPMENT

- A. General: Provide all lighting equipment and lamps as shown on drawings and as called for in these Specifications. Provide all such equipment fully complete and prewired. Install all equipment in a secure and substantial manner, and in full accord with Manufacturer's recommendations. Provide all such miscellaneous installation equipment such as support, hangers, yokes, flanges, etc., as is necessary. Provide 1-1/2 inch spacer, finished, factory approved type, between tops of fluorescent fixtures and combustible ceiling materials as required by code. Provide for aiming of all adjustable lighting fixtures as directed by Architect; exterior fixtures shall be adjusted at night.
B. Fixtures (Luminaires): All fixtures exposed to weather or cold temperatures shall be weatherproof and suitable for efficient operation at temperatures and conditions concerned. All fixtures shall bear UL label for its particular application, or as indicated; 32 watt super T8 fluorescent shall be rapid start, 20 watt shall be trigger start. Install surface or pendant mounted luminaires true and straight. Provide plaster frames or similar type devices compatible with ceiling construction for all recessed fixtures.

2.16 DEVICES AND PLATES:

- A. Receptacles: Provide the following flush receptacle devices where indicated and required. Verify color with Architect prior to installation. All devices to be Specification Grade with screw type terminals. Provide as shown or acceptable equal.
1. Devices:
a. 20A-3W, 3rd, duplex dedicated outlet Leviton-5263-White
b. WP 1R 1R 1R, duplex TayMac-503-SIG, A4
c. For GFI TayMac-526A4
c. Ground Fault 20 amp Leviton-6899-White
2. Switches
a. 20A switches Leviton-1221-White
b. 3-way switches Leviton-1223-White
3. Coverplates
a. Finished and unfinished areas are to provide .040 smooth nylon White finished coverplates.

PART 3 - EXECUTION

- A. All exterior mounted disconnects 12 feet and less above finished grade shall have padlocks; master laminated type minimum 3/16 inch shafts, master keyed, to lock disconnect doors

3.4 CONDUCTORS:

- A. Conductors shall be continuous from outlet to outlet or J-box. Splices shall be held to a minimum. Where necessary, splice in readily accessible pull box, J-box, or outlet box. The joint insulation value shall equal that of the conductor. Splices and connections shall be made in an approved manner.
B. Install wiring in the raceway systems only after the conduit run has been completed and after such time as conduits have been thoroughly cleaned and dried.
C. Enclose underground/exterior conductors in conduit schedule 40 PVC. All secondary and exterior branch circuit conductors to be buried a minimum of 30 inches below finished grade. Provide 2 inches of sand fill above and below conductors and install electrical marker tape 6 inches above all runs.
D. Wire and cable No. 6 and smaller shall be factory color coded. Where factory color is not available, or where on short runs factory color coding is not practical, mark conductors on each end and in J-boxes or pull boxes with 1" band of colored pressure sensitive plastic tape or by the use of brilliant waterproof lacquer properly applied. Colors for each phase and the neutral shall be consistent throughout the system.
1. The following color code prevails for all service, feeder and branch circuits:
Neutral White for 120V
Ground Green
Phase A Black for 120/208V
Phase B Red for 120/208V
Phase C Blue for 120/208V

- E. Wire and cable shall be the proper size to fit under lug landings in accordance with UL listing. Where larger wire and cable is used for voltage drop, etc., and will not fit under UL lug listings, Electrical Contractor shall provide proper wire and cable size under lugs and either pigtail to larger wire and cable or use power tap blocks. Provide insulation value equal to the wire and cable being used.
F. High Compression Termination: Provide high compression terminations for connecting smaller conductors to larger for voltage drop issues as shown on drawings. H-type compression tap connectors shall be for copper combinations, sized for correct conductor installation using 15 ton and 12 ton head tools per manufacturer UL listed. Manufacturer Thomas and Betts. Compression taps series 63100 with high compression tool. Provide shop drawings. Provide interlocking insulating hard covers and secure with tape sealant per manufacturer. UL listed. Manufacturer Thomas and Betts Series HTXC00 (H-Tap Insulating Hard Covers), and HSTS25 Series. Provide shop drawings.

- G. Terminations Exterior
1. Terminations shall be silicone filled safety connectors. Connector body shall consist of color-coded shell of non-hygroscopic material, with ribs or wings for easy grip and vibration-absorbing retention fingers. Inside shall be a non-setting, non-conductive, fire-retardant silicone sealant that eliminates the possibility of corrosion and flashover. The connector shall have a plated, conical, square-wire spring to draw in conductors securely as torque is applied.
2. Connectors shall be King Technology's Model King-1, 2, 3, 4, 5, 6, and/or 9 wire connectors for pressure-type locations or accepted equal.
H. Provide cable wraps (nylon ty wraps) around branch circuit bundles and feeder bundles in all switchboards, panelboards, and loadcenters.

- 3.5 CONDUCTOR NEUTRAL APPLICATIONS
A. Neutrals: Copper, same size as phase conductor, derating neutrals not allowed.
B. Feeder neutrals to lighting or computer panels shall be 200 percent.
C. Provide separate Neutral conductors for each 15 or 20 amp (120 or 277V) single pole breaker, the following application:
1. Lighting circuits.
2. Computer circuits.
3. Kitchen circuits.
4. Electronic equipment.
5. All circuits using common raceway or provide tie handles on branch circuit breaker per NEC 2008.

- 3.6 CONDUITS:
A. Slab on grade: Conduits shall not be located in slab but 6" below, thus cutting of slab will not damage conductors and conduit.
B. All conduits shall be installed concealed in finished areas. Exposed conduits will be permitted only at surface cabinets, in mechanical equipment rooms, and as otherwise permitted by Architect.
C. Route all conduits either parallel or perpendicular to walls and structural members, always avoiding proximity to sources of heat such as flues, hot water lines, etc. Runs which are buried below the floor slab or underground may be run direct (angular) to fullest practical extent. Locate raceways so as not to endanger the strength of any structural members. All runs pertinent to the building structural system shall be installed only when and in manner as approved by Architect. Actual conduit runs are not necessarily indicated, but are to be installed in the most feasible manner compatible with building construction and work of other crafts. Outlets shown connected together must be wired on the same circuit.
D. All bends to be made by the use of an approved bending tool. Cut all conduits square and ream all cuts to remove burrs. Exercise all necessary precautions during the construction period to prevent entry or accumulation of moisture, dust, concrete, and all foreign matter into the raceway system. Clean and dry all raceways prior to pulling conductors.
E. Secure all raceway systems in building structure in a rigid and secure manner using approved type fasteners such as "Caddy Clips" or similar type of other manufacturer. The use of wire, plumber's straps, etc., will not be permitted. Locations and spacing of fasteners to be as required by NEC.
F. Conduit hangers, clamps, light fixtures, supports, nails, etc., shall be fastened to joists or beams only. Do not support from bottom of roof decking or mechanical ductwork.
G. Notching of wood studs (where used) for conduit routing shall not be allowed. Drill center of studs if hole gets closer than 1" to face of studs. Provide 3/16" steel protective plates.
H. All roof penetrations done by Electrical Contractor must conform to General Contractor's standard criteria and shall be subject to his authorized Roofing Contractor. General Contractor shall pay all such costs directly to Roofing Contractor upon demand.
I. Conduits penetrating through fire-rated walls and floor slabs shall be sealed against the spread of fire and products of combustion with smoke-rating of the floor or wall through which conduits pass. See Drawings for additional requirements.

- 3.7 WIRING ABOVE SUSPENDED CEILINGS
A. Approved Class II wiring systems such as controls, telephone, intercom, TV, Fire Alarm, etc., may be routed without conduit on bridled rings. (5 feet on center and neatly trained) where above suspended accessible ceiling systems unless otherwise indicated. Where wiring runs occur in inaccessible construction such as underfloor, in walls, above gypsum board ceilings, etc., provide all necessary outlets and conduits stubbed into nearest accessible suspended ceiling space. Wiring in all exposed areas shall be routed in conduit such as, exposed ceiling, surface mounted on walls and etc. All conduit stubs shall be tagged. Where suspended ceiling plenums are used for transportation of environmental air and where required by local inspection authority, all Class II wiring runs shall be enclosed in an approved raceway system or Teflon cable approved for return air plenum application. This shall include all systems such as telephone, data, etc., even though this Contractor is not providing the cables or conductors. Refer to Article 300-22 of NEC 2017.
B. Where suspended ceiling plenums are used for transportation of environmental air and where required by local inspection authority, all Class II wiring runs shall be enclosed in an approved raceway system or Teflon cable approved for return air plenum application. This shall include all systems such as telephone, etc., even though this Contractor is not providing cables or conductors. Refer to Article 300-22 of NEC.

- 3.8 OUTLETS:
A. Install all outlets in a secure and substantial manner and locate so as to be compatible with space, construction and installation requirements, and with the work of other trades. Verify final outlet locations with Architect prior to installation. Install all outlets plumb and in accessible locations. Flush outlets are to be installed with front of box or ring flush with finished surface. All outlets are to be installed flush unless used in conjunction with exposed conduit system or unless otherwise indicated. If outlets are not installed plumb, flush, level or in approved locations, relocate or reset and reshield at no additional cost to Owner.
B. Lighting outlets: Install flush wall or ceiling outlets to accommodate type of fixture to be installed. Provide 3/8" no-bolt fixture stud in all outlets where required by weight of fixture.
C. Mount all weatherproof (WP) outlets vertically.
D. J-boxes shall not be stacked atop or use of multiple extension rings on each other to form single J-boxes. Single J-boxes shall be used of proper size per NEC.

- 3.9 LIGHTING EQUIPMENT
A. Recessed fixtures shall be connected from a J-box above the ceiling with flexible conduit. The supply conductors to recessed fixtures shall be in accordance with Manufacturer's label or as specified, whichever is more stringent. Cut openings in ceilings for outlets or recessed fixtures so that fixture or trim completely covers the openings when installed.
B. Recessed fixtures in suspended T bar grid ceilings: Overall dimensions of fixtures to be recessed with grid ceiling must be such that they will fit without distortion to the T bars. No field modification of fixtures will be allowed. Install fixtures only after such time as all adjacent T bars have been installed and supported from the superstructure at each corner of the fixture. Provide bar hangers supported from and secured to adjacent T bars to support incandescent fixtures. Fixtures must not be supported from ceiling panels. Fixture must be securely fastened, however, to ceiling framing member as required by NEC 410.16.

- 3.10 COVERPLATES
A. Install oversized or "mistake plates" for any outlet where standard sized plate will not cover rough in opening. Provide ganged plates for combination devices and multiple device installation as required. Install plates with holes sized to accommodate cable to be installed for all telephone and computer outlets.
B. Provide blank coverplate for all unused outlet boxes, i.e. voice, data, and power outlets at time of final observation.

- 3.11 FIRE PENETRATIONS
A. Provide fire rated stops to maintain fire ratings of walls, ceilings and floors.
B. Conduits may penetrate the walls, ceilings, floors or partitions provided fire stopping is provided per current International Building Code.
END OF SECTION 16100

SECTION 16400 - ELECTRICAL SYSTEMS

PART 1 - GENERAL

- 1.1 Furnish and install a complete electrical system as shown on drawings and specifications.

PART 2 - PRODUCTS

2.2 GROUNDING SYSTEM:

- A. Ground the entire electrical distribution system, including all raceways, outlets, fixtures, equipment, etc., in full accord with NEC.
B. Provide separate grounding conductor in all raceways.
C. Provide separate grounding jumper from the grounding screw of all receptacle devices to the metallic box in which mounted. Jumper may attach to box with a separate grounding screw or clip device. Jumpers may be eliminated if approved self-grounding devices are used.
D. Provide separate bonding conductor, bare copper, for runs of flexible conduit where required by NEC.
E. Provide separate grounding conductor in all runs to exterior lighting standards, such as post lights, signs, etc.
F. All conductors used for grounding and bonding purposes shall be copper, insulated green, only.

- END OF SECTION 16400

SECTION 16900 - ELECTRICAL COMPLETION

PART 1 - GENERAL

- 1.1 GENERAL:
A. The entire electrical system shall be left in first-class workable operating condition and all work shall be complete.
PART 2 - PRODUCTS
2.1 DIRECTORY CARDS:
A. Provide labels and neatly typed directory cards for all new and existing panelboards and loadcenters. Directory cards shall indicate the general area and type of electrical load served by each circuit.
PART 3 - EXECUTION
3.1 CLEAN UP:
A. Remove all materials, scrap, etc., relative to the electrical installation and leave the premises in a clean, orderly condition. Any costs to Owner for clean-up of the site will be charged against Contractor.
B. Clean all electrical equipment and materials of all foreign matter. Clean all light fixtures using only methods and materials as recommended by Manufacturer.
3.2 ACCEPTANCE DEMONSTRATION:
A. Upon completion of the work, at a time to be designated by Architect, Contractor shall demonstrate to Owner the operation of the entire electrical installation, including any and all special systems provided under this contract.
3.3 TEMPORARY WIRING:
A. Remove all temporary wiring, outlets, etc., complete.
3.4 DRAWINGS:
A. Deliver Record Drawings to Owner.

- END OF SECTION 16900



POUDRE SCHOOL DISTRICT
OLANDER ELEMENTARY SCHOOL
5401 AUNTIE STONE STREET
FORT COLLINS, CO 80526



03/02/2020

Table with 3 columns: No., Revision, Date

Sheet Title: ELECTRICAL SPECIFICATIONS

Table with 2 columns: CONSTRUCTION SET, Sheet E201



G:\Projects_2019\PSD_Early Childhood Education in Classroom Restrooms (W) - 19097\Drawings\Olander\19097-E201.dwg Mar 02 2020 - 7:54pm blue

PLUMBING GENERAL NOTES AND SPECIFICATIONS:

- ALL WORK SHALL BE IN ACCORDANCE WITH APPLICABLE LOCAL AND STATE CODES INCLUDING BUT NOT LIMITED TO THE 2015 INTERNATIONAL BUILDING, FIRE, MECHANICAL, PLUMBING, FUEL GAS, AND ENERGY CONSERVATION CODES (IBC, IFB, IMC, IPC, IFGC, IECC) WITH LOCAL AMENDMENTS.
- CONTRACTOR AND SUB-CONTRACTORS SHALL PROVIDE ALL LABOR, MATERIAL AND EQUIPMENT TO COMPLETE ALL WORK SHOWN ON PLANS, CALLED FOR IN SPECIFICATIONS, OR REASONABLY IMPLIED FOR A COMPLETE INSTALLATION.
- CONTRACTOR SHALL VERIFY ALL DIMENSIONS AND CONDITIONS ON DRAWINGS WITH ACTUAL FIELD CONDITIONS. COORDINATE DRAWINGS WITH ACTUAL FIELD CONDITIONS. COORDINATE WORK LAYOUTS AND LOCATIONS OF OPENINGS THROUGH FLOORS, WALLS, CEILINGS AND ROOFS WITH DRAWINGS OR OTHER REQUIREMENTS. VERIFY ALL DIMENSIONS AND CONDITIONS PRIOR TO FABRICATION OR CONSTRUCTION AND NOTIFY ENGINEER OF ANY DISCREPANCIES.
- PLUMBING DRAWINGS ARE DIAGRAMMATIC AND DO NOT NECESSARILY INDICATE REQUIRED OFFSETS, FITTINGS, ETC. DO NOT SCALE DRAWINGS, USE DIMENSIONS ONLY. ALL DIMENSIONS/LAYOUTS SHOWN ARE APPROXIMATE, FIELD VERIFY ALL WORK PRIOR TO ORDERING MATERIALS OR INSTALLING WORK
- KEEP SITE AND BUILDING ACCESSIBLE AND SAFE TO CONTRACTOR'S PERSONNEL, OWNER'S EMPLOYEES AND PUBLIC AT ALL TIMES. CONTRACTOR SHALL ENSURE SAFETY OF PERSONNEL, OWNER AND PUBLIC DURING ALL WORK AND COMPLY WITH ALL APPLICABLE REGULATIONS AND ORDINANCES PERTAINING TO SAFETY OF PERSONS AND PROPERTY.
- INSTALL ALL WORK IN STRICT ACCORDANCE WITH THE MANUFACTURERS RECOMMENDATIONS, ANCHORING ALL COMPONENTS PLUMB, LEVEL, SQUARE, AND FIRMLY INTO PLACE IN FIRST CLASS MANNER AND WORKMANSHIP ACCORDING TO STANDARD CONSTRUCTION PRINCIPLES & AS APPROVED BY ENGINEER.
- THROUGHOUT THE WORK, CAULK AND SEAL ALL JOINTS REQUIRED TO PROVIDE A POSITIVE BARRIER AGAINST THE PASSAGE OF AIR AND MOISTURE.
- PROTECT EXISTING OR ADJACENT SITE IMPROVEMENTS, EXISTING FLOOR, WALL, CEILING AND ROOF FINISHES, FURNISHINGS AND EQUIPMENT TO REMAIN DURING CONSTRUCTION, REPLACE OR REPAIR ANY DAMAGED IMPROVEMENTS, MATERIALS, FINISHES, FURNISHINGS OR EQUIPMENT TO SATISFACTION OF ARCHITECT/ENGINEER.
- REPLACE OR REPAIR ANY DAMAGED SURFACES, FILL AND PATCH HOLES, ETC., TO MATCH ADJACENT SURFACES AFTER ALL ALTERATIONS AND OTHER WORK IS COMPLETED, TO SATISFACTION OF ARCHITECT/ENGINEER.
- PRIOR TO THE DEMOLITION OF ANY EXISTING EQUIPMENT, COORDINATE WITH THE OWNER TO DETERMINE WHAT EQUIPMENT THEY MAY WANT TO KEEP. ANY EQUIPMENT NOT WANTED BY THE OWNER SHALL BECOME THE PROPERTY OF THE GENERAL CONTRACTOR AND SUBCONTRACTORS AND SHALL BE REMOVED FROM THE PROJECT SITE AND DISPOSED OF IN A LAWFUL MANNER.
- THE ENGINEER HAS ENDEAVORED TO LOCATE AND IDENTIFY THE PLUMBING EQUIPMENT AND PIPING IN THE SCOPE OF WORK INCLUDING IDENTIFYING SIZES. HOWEVER, IT IS THE CONTRACTOR'S RESPONSIBILITY TO FIELD VERIFY ALL EXISTING CONDITIONS PRIOR TO BID. THE CONTRACTOR SHALL INCLUDE IN THEIR BID ADDITIONAL MINOR MECHANICAL WORK THAT MAY NOT BE SHOWN IN ORDER TO PROVIDE A COMPLETE AND WORKING SYSTEM.
- ASBESTOS MAY BE ENCOUNTERED DURING MECHANICAL WORK INCLUDING BUT NOT LIMITED TO PIPE INSULATION. IF THE CONTRACTOR DURING CONSTRUCTION ENCOUNTERS WHAT IS BELIEVED TO BE ASBESTOS CONTAINING MATERIALS, NOTIFY THE ENGINEER IMMEDIATELY.
- WHERE THE CEILING SPACE IS TO BE USED AS A RETURN AIR PLENUM, THE MECHANICAL CONTRACTOR SHALL VERIFY WITH OTHER TRADES TO ENSURE THAT ALL MATERIALS ARE NON-COMBUSTIBLE AND HAVE A FLAME SPREAD INDEX OF NOT MORE THAN 25 AND A SMOKE DEVELOPED INDEX OF NOT MORE THAN 50 - REFER TO MECHANICAL PLANS.
- COORDINATE WITH THE G.C. TO PROVIDE ACCESS PANELS AS REQUIRED TO ACCESS VALVES, PLUMBING ACCESSORIES, ETC. REQUIRED FOR THE PROPER MAINTENANCE OF THE PLUMBING SYSTEMS.
- COORDINATE WITH G.C. TO PATCH ROOFING, ROOF DECK, AND FLASHINGS AS REQ'D WITH NEW MATERIALS AND FLASHINGS FOR ALL NEW ROOF PENETRATIONS.
- DO NOT RUN PIPES ABOVE ELECTRICAL PANELS OR EQUIPMENT. COORDINATE WITH THE E.C. FOR LOCATIONS PRIOR TO THE START OF WORK.
- SEE THE PLUMBING FIXTURE CONNECTION SCHEDULE FOR MINIMUM PIPE SIZES TO THE FIXTURES. PROVIDE AN INCREASER/REDUCER AS REQUIRED AT THE FIXTURE CONNECTION.
- DOMESTIC WATER PIPING SHALL BE TYPE 'L' COPPER ASTM B88 WITH ASME B16.18 CAST COPPER OR ASME B16.22 WROUGHT COPPER FITTINGS, JOINTS SHALL BE MADE WITH LEAD-FREE SOLDER.
- PIPING INSULATION SHALL BE INSTALLED BY A QUALIFIED INSULATION CONTRACTOR WITH A MINIMUM OF 3-YEARS DOCUMENTED EXPERIENCE. INSULATION WORK SHALL BE COMPLETE WITH ALL EDGES SEALED, PER INDUSTRY STANDARDS, AND TO THE SATISFACTION OF THE ENGINEER. SEE THE FOLLOWING PARAGRAPHS FOR INSULATION REQUIREMENTS.
 - DOMESTIC COLD WATER: 0.5" THICK (PIPES 1/2" AND SMALLER), 1" THICK (PIPES 1/2" AND LARGER)
 - DOMESTIC HOT WATER: 1" THICK (PIPES 1/2" AND SMALLER), 1 1/2" THICK (PIPES 1/2" TO 4")
 - DOMESTIC HOT WATER RECIRC: 1" THICK (ALL SIZES).
- PROVIDE AND INSTALL PIPE HANGERS IN ACCORDANCE WITH MSS SP-58. PIPE HANGERS SHALL HAVE A GALVANIZED INSULATION SADDLE (1 1/2" AND SMALLER) OR PIPE INSERT (2" AND LARGER) TO PROTECT INSULATION.
- WASTE & VENT PIPING (EXCEPT IN RETURN AIR PLENUM-RE: MECHANICAL):
 - SOLID CORE SCHEDULE 40 PVC, ASTM D2665. FITTINGS SHALL BE ASTM D2665. JOINTS SHALL BE ASTM D2855 SOLVENT WELD WITH ASTM D2564 SOLVENT CEMENT. CELLULAR CORE IS NOT ACCEPTABLE.
 - USE PURPLE PVC PRIMER. CLEAR PRIMER NOT ACCEPTABLE.
- WASTE AND VENT PIPING (IN RETURN AIR PLENUM-RE: MECHANICAL):
 - CAST IRON PIPE, CISPI 301, HUB-LESS, SERVICE WEIGHT. FITTINGS SHALL BE CAST IRON, CISPI 301. JOINTS SHALL BE CISPI 310, NEOPRENE GASKETS AND STAINLESS STEEL CLAMP-AND-SHIELD ASSEMBLIES.
- DOMESTIC WATER PIPING MAY NOT BE INSTALLED IN ANY EXTERIOR WALLS.
- ACCEPTABLE VALVE MANUFACTURERS: APOLLO VALVE, CRANE VALVE, HAMMOND VALVE, MILWAUKEE VALVE COMPANY, NIBCO, STOCKHAM VALVES AND FITTINGS OR PRIOR APPROVED EQUAL.
- ALL VALVES USED ON DOMESTIC WATER SYSTEMS SHALL BE LEAD FREE AND NSF RATED.
- BALL VALVES 2" AND SMALLER: NSF 61 COMPLIANT, MSS SP110, 600 PSI WOG, TWO PIECE BRONZE BODY, CHROME PLATED BRASS BALL, FULL PORT, TEFLON SEATS, BLOW-OUT PROOF STEM, SOLDER OR THREADED ENDS, EXTENDED LEVER HANDLE AS REQUIRED FOR OPERATION WITH PIPING INSULATION.
- MANUAL BALANCING VALVES: NSF 61 COMPLIANT, 400 PSI AT 250°F, BALL TYPE VALVE WITH CALIBRATED NAMEPLATE AND MEMORY STOP. LEAD-FREE BRASS BODY WITH THREADED ENDS. DIFFERENTIAL PRESSURE READOUT PORTS WITH INTERNAL CHECK VALVES. STAINLESS STEEL BALL, TEFLON SEAT RINGS, AND EPDM O-RING. 1/4" TAPPED DRAIN/PURGE PORT.
- HORIZONTAL SWING CHECK VALVES 2" AND SMALLER: NSF 61 COMPLIANT, MSS SP 80, CLASS 125, BRONZE BODY AND CAP, Y-PATTERN, BRONZE REGRINDING DISC, SOLDER OR THREADED ENDS.
- SPRING LOADED CHECK VALVES 2" AND SMALLER: NSF 61 COMPLIANT, MSS SP 80, CLASS 125, BRONZE BODY, IN-LINE SPRING LIFT CHECK, SILENT CLOSING, BUNA-N DISC, INTEGRAL SEAT, SOLDER OR THREADED ENDS.
- PROVIDE BALL VALVES ON ALL BRANCH WATER LINES WHETHER SHOWN ON THE PLANS OR NOT.
- REFERENCE ARCHITECTURAL PLANS FOR EXACT FIXTURE LOCATIONS. EXAMINE ROUGH-IN FOR WATER AND WASTE PIPING. USE MANUFACTURER'S ROUGH-IN DIMENSIONS. ADJUST EXISTING AS REQUIRED. REFER TO THE ARCHITECTURAL PLANS FOR EXACT FIXTURE LOCATION DIMENSIONS.
- OFFSET FLANGES AND CROSS FITTINGS ARE NOT PERMITTED.
- INSTALL PLUMBING FIXTURES LEVEL AND PLUMB. SEAL AROUND FIXTURES TO WALL OR FLOOR WITH SEALANT TO MATCH FIXTURE. CLEAN ALL FIXTURES BEFORE TURNING OVER TO THE OWNER.
- PROVIDE A QUARTER TURN STOP ON THE WATER SUPPLY TO EACH PLUMBING FIXTURE. INSTALL STOPS SO THAT THEY ARE EASILY ACCESSIBLE. ALL SUPPLIES AFTER THE STOPS TO BE RIGID CHROME PLATED.
- ALL PIPE PENETRATIONS THROUGH THE FLOORS AND WALLS SHALL BE SLEEVED WITH GALVANIZED STEEL. SLEEVES SHALL BE LARGE ENOUGH TO ALLOW FOR INSULATION TO BE CONTINUOUS THROUGH THE SLEEVE. SEAL AROUND SLEEVES AND PROVIDE CHROME PLATED ESCUTCHEONS IN FINISHED SPACES.
- WHERE PIPES PENETRATE A FIRE RATED ASSEMBLY PACK THE VOID WITH BACKING MATERIAL AND SEAL WITH UL LISTED FIRE CAULK TO MEET THE FIRE RATING OF ASSEMBLY PENETRATED. REFER TO ARCHITECTURAL PLANS FOR LOCATIONS AND TYPES OF FIRE RATED ASSEMBLIES.
- INSTALL TRAP AND VENT ON THE DRAIN OUTLET OF EACH FIXTURE TO BE DIRECTLY CONNECTED TO THE SANITARY SEWER SYSTEM. EXPOSED P-TRAPS LOCATED UNDER SINKS TO BE 17 GA. CHROME WITH CLEANOUT.
- WALL CLEANOUTS IN FINISHED AREAS SHALL BE LINE TYPE WITH ROUND STAINLESS STEEL ACCESS COVER SECURED WITH MACHINE SCREWS.
- FLOOR AND GRADE CLEANOUTS IN FINISHED AREAS SHALL BE LINE TYPE, CAST IRON BODY WITH ADJUSTABLE RISER, NO-HUB OUTLET. CAST IRON FRAME AND GRATE COVER AND INTERNAL PLUG.
- PLUMBING VENTS THROUGH THE ROOF SHALL BE 3" MINIMUM. WHERE THE CONNECTING PIPE IS SMALLER, THE PIPE SHALL TRANSITION A MINIMUM OF 12" BELOW THE ROOF STRUCTURE AND THEN EXTEND THROUGH THE ROOF AS A 3" PIPE.
- COORDINATE EXACT LOCATION OF EQUIPMENT AND ROUTES TO AND FROM EQUIPMENT WITH STRUCTURE AND CONDITIONS. THE CONTRACTOR IS RESPONSIBLE FOR OFFSETS OF PIPING TO AVOID CONFLICTS. NOT ALL OFFSETS, FITTINGS, EXTENSIONS SHOWN THAT MAY BE REQUIRED DURING CONSTRUCTION
- LABEL ALL DOMESTIC WATER, WASTE, VENT, AND GAS PIPES WITH NAMES AND FLOW ARROWS. LABELS SHALL BE NOT MORE THAN 10'-0" APART AND SHALL BE LOCATED AT ALL ACCESS LOCATION TO CONCEALED SPACES. EXTERIOR GAS PIPING TO HAVE STENCIL PAINT LABELS AND FLOW ARROWS.
- TEST ALL WATER, WASTE, AND VENT PIPING IN ACCORDANCE WITH THE INTERNATIONAL PLUMBING CODE AND PER THE LOCAL AUTHORITY HAVING JURISDICTION. ALL TESTS, INSPECTIONS, AND PIPE FLUSHING TO BE WITNESSED BY THE PSD PLUMBING DEPARTMENT.
- ALL DOMESTIC HOT WATER RECIRCULATION SYSTEMS SHALL BE BALANCED TO THE QUANTITIES SHOWN. THE BALANCING FIRM SHALL EITHER BE AABC OR NEBB CERTIFIED AND SHALL SUBMIT A BALANCE REPORT TO THE ENGINEER FOR REVIEW.
- THE PLUMBING CONTRACTOR SHALL PROVIDE PRODUCT DATA SUBMITTALS FOR ALL THE PLUMBING EQUIPMENT SCHEDULED, PLUMBING FIXTURES, PIPING, PIPE INSULATION, AND VALVES. ALL EQUIPMENT SUBMITTALS SHALL BE REVIEWED BY THE ENGINEER PRIOR TO THE START OF WORK.
- THE CONTRACTOR SHALL PROVIDE THE OWNER WITH (1) FULL SIZE SET OF THE AS-BUILT PLUMBING DRAWINGS WHICH SHALL SHOW THE ACTUAL LOCATIONS OF PIPES, VALVES, FIXTURES, AND ACCESSORIES OR ANY OTHER DEVIATIONS FROM THE DESIGN DRAWINGS.
- THE CONTRACTOR SHALL PROVIDE THE OWNER WITH (1) COPY OF ALL OPERATIONAL AND MAINTENANCE (O&M) MANUALS FOR EACH PIECE OF EQUIPMENT. THE MANUAL SHALL INCLUDE: THE CONTRACTOR'S CONTACT INFORMATION, THE MANUFACTURER'S PUBLISHED O&M INSTRUCTIONS, THE APPROVED SUBMITTAL DRAWINGS, AND THE FINAL APPROVED TEST AND BALANCE REPORT. COMBINE ALL THE MANUALS IN A 3-RING BINDER INDEXED FOR EACH PIECE OF EQUIPMENT. ALSO PROVIDE THE OWNER A CD WITH THE ENTIRE O&M MANUAL IN PDF FORMAT.
- THE CONTRACTOR SHALL PROVIDE OWNER TRAINING ON THE OPERATION AND MAINTENANCE OF THE PLUMBING EQUIPMENT.

SHEET INDEX:

P001	PLUMBING NOTES & LEGEND
P101	PLUMBING PLANS
P301	PLUMBING SCHEDULES & DETAILS

PLUMBING LEGEND

	EXISTING PIPE
	PIPE DEMOLITION
	DOMESTIC COLD WATER
	DOMESTIC HOT WATER
	DOMESTIC HOT WATER
	WASTE PIPE (DASHED BELOW GROUND)
	WASTE PIPE (SOLID ABOVE GROUND)
	VENT PIPE
	BALL VALVE, PRESSURE REDUCING VALVE
	CONTROL VALVE, CHECK VALVE
	UNION OR FLANGE, REDUCER/INCREASER
	PIPE ELBOW UP, PIPE ELBOW DOWN
	TEE UP, TEE DOWN
	POINT OF CONNECTION
	LIMIT OF DEMOLITION

ABBREVIATIONS

AAV	AIR ADMITTANCE VALVE
AFF	ABOVE FINISHED FLOOR
BLW	BELOW
CLG	CEILING
DCW	DOMESTIC COLD WATER
DHW	DOMESTIC HOT WATER
DHWC	DOMESTIC HOT WATER CIRCULATION
DWH	DOMESTIC WATER HEATER
DN	DOWN
(E)	EXISTING
EC	ELECTRICAL CONTRACTOR
FCO	FLOOR CLEANOUT
FDC	FIRE DEPARTMENT CONNECTION
FD	FLOOR DRAIN
FS	FLOOR SINK
FSS	FIRE SPRINKLER CONTRACTOR
GCO	GRADE CLEANOUT
IFGC	INTERNATIONAL FUEL GAS CODE
IMC	INTERNATIONAL MECHANICAL CODE
IPC	INTERNATIONAL PLUMBING CODE
LAV	LAVATORY
NEW	NEW
NC	NORMALLY CLOSED
POC	POINT OF CONNECTION
(REL)	RELOCATED
SL	SEA LEVEL
TYP	TYPICAL
VTR	VENT THROUGH ROOF
W/	WITH
W/O	WITHOUT
WC	WATER CLOSET

BID ALTERNATE NOTES:

- BASE BID: DOMESTIC HOT WATER RECIRCULATION PUMP TO BE CONTROLLED BY PUMP MANUFACTURER PROVIDED 7-DAY PROGRAMMABLE TIME CLOCK AND AQUASTAT TO MEET THE SEQUENCE OF OPERATION, SHEET P301.
- BID ALTERNATE #3:
 - DOMESTIC HOT WATER RECIRCULATION PUMP TO BE CONTROLLED BY THE BUILDING DDC SYSTEM IN LIEU OF THE STAND-ALONE TIME CLOCK AND AQUASTAT.
 - EXISTING BUILDING DDC SYSTEM IS A SPYDER. APPROVED VENDOR IS BUILDING TECHNOLOGY SYSTEMS (BTS).

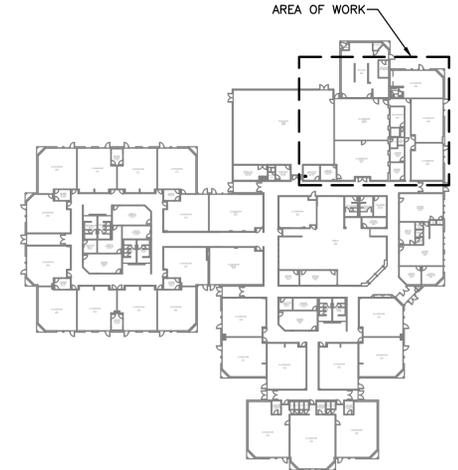

KEY PLAN
SCALE: NONE



POUDRE SCHOOL DISTRICT
 OLANDER ELEMENTARY SCHOOL
 5401 AUNTIE STONE STREET
 FORT COLLINS, CO 80526

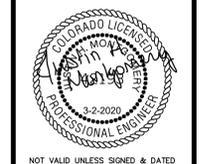

No.	Revision	Date

Sheet Title:
PLUMBING NOTES & LEGEND

Project EC REST ROOMS	
CONSTRUCTION SET	
Date 5/2/2020	Sheet P001
Scale	

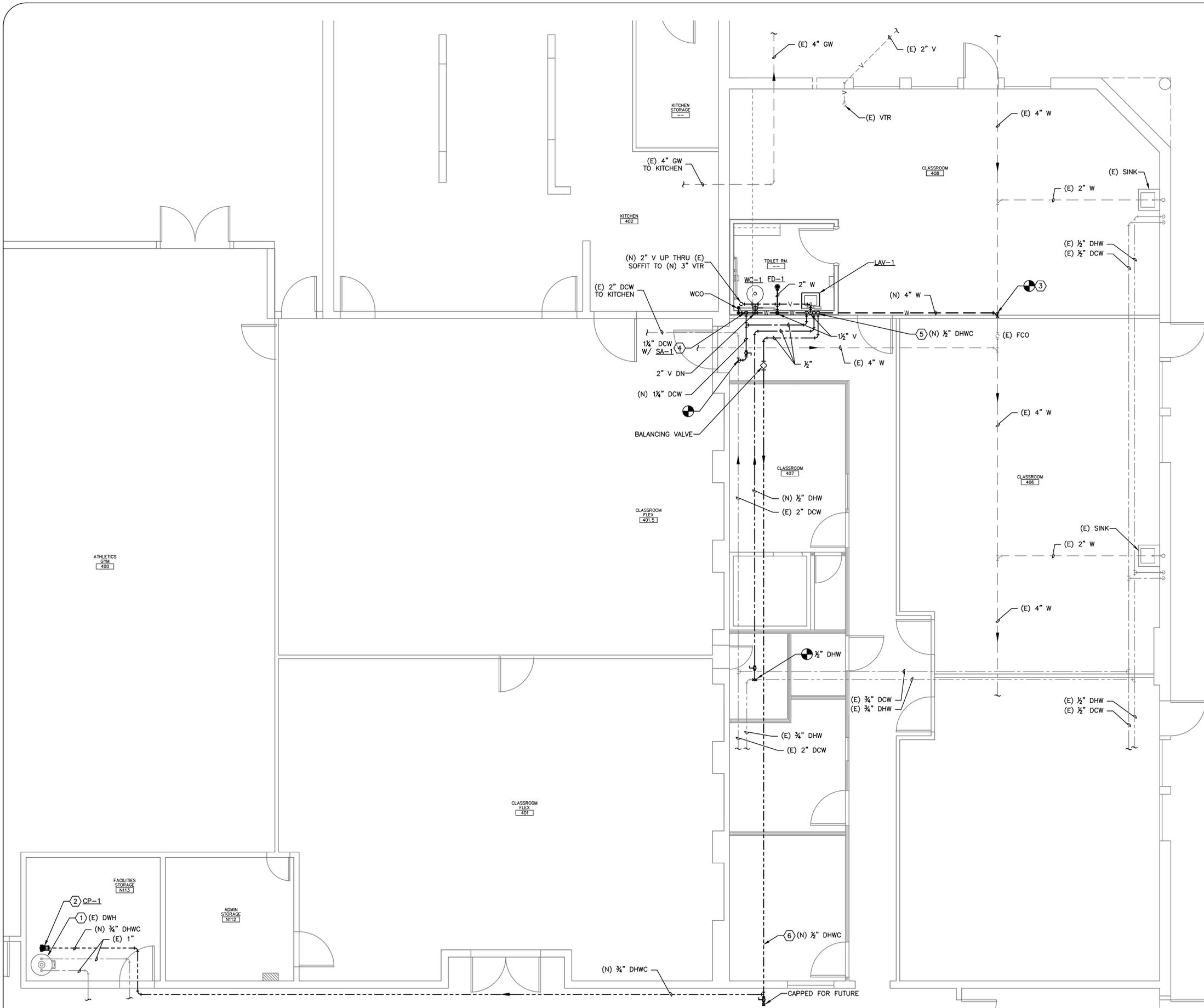

FLAG NOTES:

1. EXISTING PLUMBING WORK TO REMAIN AS IS.
2. NEW DOMESTIC HOT WATER CIRCULATOR PUMP. SEE DOMESTIC WATER HEATER DETAIL, SHEET P301.
3. CONNECT TO EXISTING 4" W BELOW THE FLOOR IN THIS AREA. CONTRACTOR TO FIELD VERIFY LOCATION AND INVERT ELEVATION PRIOR TO THE START OF WORK. COORDINATE W/ G.C. FOR FLOOR CUTTING AND PATCHING.
4. INSTALL SHOCK ABSORBER WITH SHUTOFF VALVE FOR FUTURE MAINTENANCE. INSTALL IN WALL, SHOWN OFFSET FOR CLARITY. COORDINATE W/ THE G.C. TO PROVIDE A PAINTED ACCESS PANEL IN THE WALL ABOVE THE TILE, RE: ARCHITECTURAL COLOR BY ARCHITECT.
5. EXTEND DHWC PIPE DOWN TO CONNECT TO DHW PIPE WITHIN 24" OF THE LAVATORY FIXTURE CONNECTION PER THE 2018 IECC.
6. ROUTE NEW DHWC PIPE BACK TO EXISTING DOMESTIC WATER HEATER.

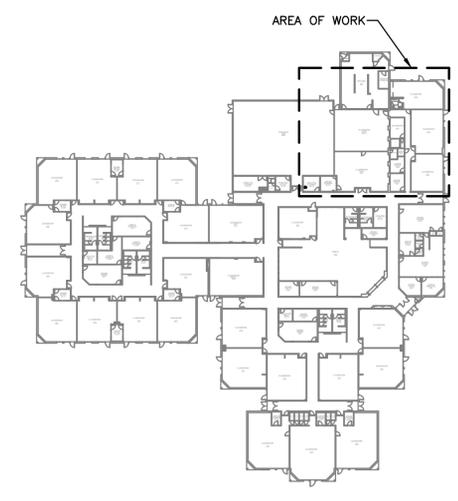

PLUMBING REMODEL PLAN
 SCALE: 1/4" = 1'-0"
 4' 0' 4' 0' 8'

KEY PLAN
 SCALE: NONE



POUDRE SCHOOL DISTRICT
 OLANDER ELEMENTARY SCHOOL
 5401 AUNTIE STONE STREET
 FORT COLLINS, CO 80526

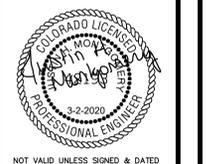

NOT VALID UNLESS SIGNED & DATED

No.	Revision	Date

Sheet Title:
PLUMBING PLAN

Project:
EC REST ROOMS
 CONSTRUCTION SET
 Date: 5/2/2020
 Sheet: P101
 Scale:

PLUMBING FIXTURE SCHEDULE

TAG	FIXTURE INFORMATION			FAUCET OR FLUSH VALVE INFORMATION			PIPE RUNOUT SIZES				REMARKS
	MAKE	MODEL	DESCRIPTION	MAKE	MODEL	DESCRIPTION	DCW	DHW	W	V	
FD-1	ZURN	Z415B	EPOXY COATED CAST IRON FLOOR DRAIN WITH ANCHOR FLANGE, REVERSIBLE CLAMPING COLLAR WITH PRIMARY AND SECONDARY WEEPHOLES, ADJUSTABLE 5" ROUND HEEL PROOF NICKEL BRONZE STRAINER, AND NO-HUB OUTLET.	--	--	--	--	--	2"	1½"	4
LAV-1	AMERICAN STANDARD	LUCERNE #0355.012	WALL HUNG LAVATORY SINK, WHITE VITREOUS CHINA WITH SELF-DRAINING DECK AREA, 5" BACKSPASH, AND FRONT OVERFLOW. 4" CENTER SET FAUCET HOLES. PROVIDE WITH PERFORATED STRAINER AND CHROME-PLATED BRASS 1-1/4" OFFSET TAILPIECE. ADA COMPLIANT.	CHICAGO	802-VE2805ABCP	HEAVY DUTY CAST BRASS DECK FAUCET WITH 4" CENTERS, CHROME FINISH, TWO QUARTER-TURN LEVER HANDLES, AND 0.5 GPM NON-AERATING SPRAY OUTLET. ADA COMPLIANT.	½"	½"	2"	1½"	1-3
SA-1	ZURN	SHOKTROL Z1700-200	TYPE 304 STAINLESS STEEL WATER HAMMER ARRESTOR WITH STAINLESS STEEL NESTING BELLOWS AND THREADED PIPE CONNECTION. PDI SIZE B. ASSE 1010.	--	--	--	¾"	--	--	--	NONE
TMV-1	LEONARD	170A-LF	ASSE 1070 LISTED THERMOSTATIC MIXING VALVE. 0.25 GPM MIN. INTEGRAL INLET FILTER WASHERS AND CHECK VALVES. LEAD FREE. PROVIDE WITH COLD WATER BYPASS AND MOUNTING BRACKET. SET OUTLET TEMP. TO 110° F.	--	--	--	½"	½"	--	--	NONE
WC-1	AMERICAN STANDARD	MADERA #3043.001	FLOOR MOUNTED FLUSHOMETER WATER CLOSET W/ ELONGATED BOWL. 1½" TOP SPUD. WHITE VITREOUS CHINA. 16½" BOWL HEIGHT. 1.28 GPF. PROVIDE WITH OPEN FRONT SOLID PLASTIC SEAT.	SLOAN	ROYAL 111-1.28	EXPOSED MANUAL FLUSHOMETER VALVE FOR TOP SPUD WATER CLOSET. POLISHED CHROME FINISH. 1.28 GPF. ADA COMPLIANT. LOCATE HANDLE TO THE OPEN SIDE OF THE ROOM.	1½"	--	4"	2"	NONE

NOTES:
 1.) PROVIDE WITH UNDER SINK PIPE INSULATION, TRUEBRO LAV GUARD 2. 2.) PROVIDE WITH THERMOSTATIC MIXING VALVE TMV-1. 3.) PROVIDE WITH FLOOR MOUNTED CONCEALED ARM CARRIER 4.) PROVIDE WITH ASSE 1072 TRAP SEAL PROTECTION DEVICE

ACCEPTABLE MANUFACTURERS:
 LAVATORY & WATER CLOSET – KOHLER OR AMERICAN STANDARD, FLOOR DRAIN & WATER HAMMER ARRESTOR – JOSAM, JR SMITH, WATTS, OR ZURN, THERMOSTATIC MIXING VALVE – LEONARD, WATTS, OR ZURN

DOMESTIC HOT WATER CIRCULATION PUMP SCHEDULE

TAG	MAKE & MODEL	FLOW (GPM)	HEAD (FT)	TYPE	VOLTAGE	AMPS	HP	BODY	IMPELLER	CONN.	REMARKS
CP-1	TACO #005-SF	4	7	WET ROTOR	115/60/1	0.54	1/35	STAINLESS STEEL	NON-METALLIC	¾"	1-4

1.) UL LISTED 2.) TACO #563-2 AQUASTAT KIT (BASE BID ONLY) 3.) TACO #265-3 7-DAY PROGRAMMABLE DIGITAL TIMER (BASE BID ONLY) 4.) OR EQUAL BY GRUNDFOS

DOMESTIC HOT WATER CIRCULATION PUMP SEQUENCE OF OPERATION

- 1.) **OCCUPIED MODE:**
 - A. WHEN THE DIGITAL TIMER IS IN OCCUPIED MODE THE CIRCULATOR PUMP SHALL BE ENABLED.
 - B. IF THE AQUASTAT DETECTS A TEMPERATURE BELOW 95°F, THEN THE PUMP SHALL BE ON.
 - C. IF THE AQUASTAT DETECTS A TEMPERATURE GREATER THAN OR EQUAL TO 115° F, THEN THE PUMP SHALL BE OFF.
- 2.) **UNOCCUPIED MODE:**
 - A. WHEN THE DIGITAL TIMER IS IN UNOCCUPIED MODE, THE CIRCULATOR PUMP SHALL BE OFF.

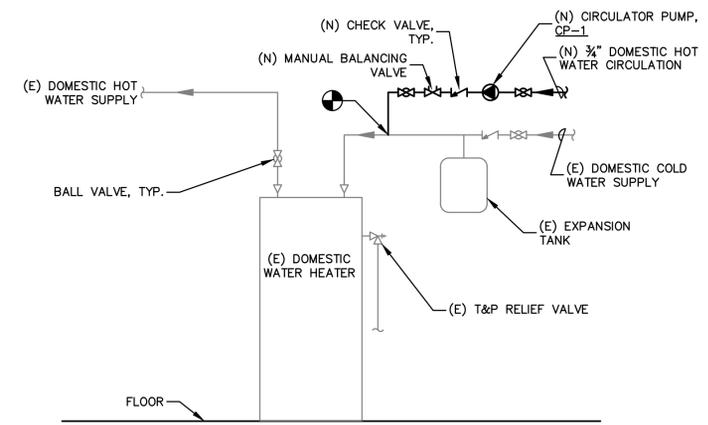

DOMESTIC WATER HEATER DETAIL

SCALE: NONE



POUDRE SCHOOL DISTRICT
 OLANDER ELEMENTARY SCHOOL
 5401 AUNTIE STONE STREET
 FORT COLLINS, CO 80526



NOT VALID UNLESS SIGNED & DATED

No.	Revision	Date

Sheet Title:
PLUMBING SCHEDULES & DETAILS

Project
EC REST ROOMS

CONSTRUCTION SET

Date
 5/2/2020
 Sheet
 P301

Scale

MECHANICAL GENERAL NOTES AND SPECIFICATIONS:

- ALL WORK SHALL BE IN ACCORDANCE WITH APPLICABLE LOCAL AND STATE CODES INCLUDING BUT NOT LIMITED TO THE 2015 INTERNATIONAL BUILDING, FIRE, MECHANICAL, PLUMBING, FUEL GAS, AND ENERGY CONSERVATION CODES (IBC, IFB, IMC, IPC, IFGC, IECC) WITH LOCAL AMENDMENTS.
- CONTRACTOR AND SUB-CONTRACTORS SHALL PROVIDE ALL LABOR, MATERIAL AND EQUIPMENT TO COMPLETE ALL WORK SHOWN ON PLANS, CALLED FOR IN SPECIFICATIONS, OR REASONABLY IMPLIED FOR A COMPLETE INSTALLATION.
- CONTRACTOR SHALL VERIFY ALL DIMENSIONS AND CONDITIONS ON DRAWINGS WITH ACTUAL FIELD CONDITIONS. COORDINATE DRAWINGS WITH ACTUAL FIELD CONDITIONS. COORDINATE WORK LAYOUTS AND LOCATIONS OF OPENINGS THROUGH FLOORS, WALLS, CEILINGS AND ROOFS WITH DRAWINGS OR OTHER REQUIREMENTS. VERIFY ALL DIMENSIONS AND CONDITIONS PRIOR TO FABRICATION OR CONSTRUCTION AND NOTIFY ENGINEER OF ANY DISCREPANCIES.
- MECHANICAL DRAWINGS ARE DIAGRAMMATIC AND DO NOT NECESSARILY INDICATE EVERY REQUIRED OFFSET, FITTING, ETC. DO NOT SCALE DRAWINGS, USE DIMENSIONS ONLY. ALL DIMENSIONS/LAYOUTS SHOWN ARE APPROXIMATE, FIELD VERIFY ALL WORK PRIOR TO ORDERING MATERIALS OR INSTALLING WORK.
- KEEP SITE AND BUILDING ACCESSIBLE AND SAFE TO CONTRACTOR'S PERSONNEL, OWNER'S EMPLOYEES AND PUBLIC AT ALL TIMES. CONTRACTOR SHALL ENSURE SAFETY OF PERSONNEL, OWNER AND PUBLIC DURING ALL WORK AND COMPLY WITH ALL APPLICABLE REGULATIONS AND ORDINANCES PERTAINING TO SAFETY OF PERSONS AND PROPERTY.
- INSTALL ALL WORK IN STRICT ACCORDANCE WITH THE MANUFACTURERS RECOMMENDATIONS, ANCHORING ALL COMPONENTS PLUMB, LEVEL, SQUARE, AND FIRMLY INTO PLACE IN FIRST CLASS MANNER AND WORKMANSHIP ACCORDING TO STANDARD CONSTRUCTION PRINCIPLES & AS APPROVED BY ENGINEER.
- THROUGHOUT THE WORK, CAULK AND SEAL ALL JOINTS AS REQUIRED TO PROVIDE A POSITIVE BARRIER AGAINST THE PASSAGE OF AIR AND MOISTURE.
- PROTECT EXISTING OR ADJACENT SITE IMPROVEMENTS, EXISTING FLOOR, WALL, CEILING AND ROOF FINISHES, FURNISHINGS AND EQUIPMENT TO REMAIN DURING CONSTRUCTION. REPLACE OR REPAIR ANY DAMAGED IMPROVEMENTS, MATERIALS, FINISHES, FURNISHINGS OR EQUIPMENT TO SATISFACTION OF ARCHITECT/ENGINEER. [Edit as required per project. Typically only for remodels or additions]
- REPLACE OR REPAIR ANY DAMAGED SURFACES, FILL AND PATCH HOLES, ETC., TO MATCH ADJACENT SURFACES AFTER ALL ALTERATIONS AND OTHER WORK IS COMPLETED, TO SATISFACTION OF ARCHITECT/ENGINEER.
- PRIOR TO THE DEMOLITION OF ANY EXISTING EQUIPMENT, COORDINATE WITH THE OWNER TO DETERMINE WHAT EQUIPMENT THEY MAY WANT TO KEEP. ANY EQUIPMENT NOT WANTED BY THE OWNER SHALL BECOME THE PROPERTY OF THE GENERAL CONTRACTOR AND SUBCONTRACTORS AND SHALL BE REMOVED FROM THE PROJECT SITE AND DISPOSED OF IN A LAWFUL MANNER.
- CONTRACTOR MUST COORDINATE THE WORK SO AS NOT TO EXTENSIVELY DISRUPT OWNERS OCCUPANCY OF ADJACENT AREAS AS APPROVED BY OWNER.
- THE ENGINEER HAS ENDEAVORED TO LOCATE AND IDENTIFY THE MECHANICAL EQUIPMENT AND PIPING IN THE SCOPE OF WORK INCLUDING IDENTIFYING SIZES. HOWEVER, IT IS THE CONTRACTOR'S RESPONSIBILITY TO FIELD VERIFY ALL EXISTING CONDITIONS PRIOR TO BID. THE CONTRACTOR SHALL INCLUDE IN THEIR BID ADDITIONAL MINOR MECHANICAL WORK THAT MAY NOT BE SHOWN IN ORDER TO PROVIDE A COMPLETE AND WORKING SYSTEM.
- ASBESTOS MAY BE ENCOUNTERED DURING MECHANICAL WORK INCLUDING BUT NOT LIMITED TO PIPE INSULATION. IF THE CONTRACTOR DURING CONSTRUCTION ENCOUNTERS WHAT IS BELIEVED TO BE ASBESTOS CONTAINING MATERIALS, NOTIFY THE ENGINEER IMMEDIATELY.
- WHERE THE CEILING SPACE IS TO BE USED AS A RETURN AIR PLENUM, THE MECHANICAL CONTRACTOR SHALL VERIFY WITH OTHER TRADES TO ENSURE THAT ALL MATERIALS ARE NON-COMBUSTIBLE AND HAVE A FLAME SPREAD INDEX OF NOT MORE THAN 25 AND A SMOKE DEVELOPED INDEX OF NOT MORE THAN 50.
- COORDINATE WITH THE G.C. TO PROVIDE ACCESS PANELS AS REQUIRED TO ACCESS VALVES, DAMPERS, CONTROL DEVICES, ETC. REQUIRED FOR THE PROPER MAINTENANCE OF THE MECHANICAL SYSTEMS.
- COORDINATE WITH G.C. TO PATCH ROOFING, ROOF DECK, AND FLASHINGS AS REQ'D WITH NEW MATERIALS AND FLASHINGS FOR ALL NEW ROOF PENETRATIONS.
- PATCH OPENINGS IN DUCTS WHICH ARE TO REMAIN ACTIVE AND HAVE HAD SECTION REMOVED. ALSO REPAIR DUCT INSULATION SO THAT IT IS CONTINUOUS.
- DO NOT RUN DUCTWORK ABOVE ELECTRICAL PANELS OR EQUIPMENT. COORDINATE WITH THE E.C. FOR LOCATIONS PRIOR TO THE START OF WORK.
- THERMOSTATS, TEMPERATURE SENSORS, SWITCHES, OR OTHER CONTROL DEVICES SHALL BE MOUNTED AT 48" ABOVE FINISHED FLOOR UNLESS NOTED OTHERWISE.
- PROVIDE PLASTIC LAMINATED EQUIPMENT LABELS FOR THE NEW EQUIPMENT. LABEL ALL THE THERMOSTATS, SWITCHES, MOTOR STARTERS, ETC. INDICATING WHICH SYSTEM THEY CONTROL.
- ALL DUCTWORK SHALL BE 24 GAUGE GALVANIZED SHEET METAL MINIMUM. WORK SHALL BE IN ACCORDANCE WITH SMACNA HVAC DUCT CONSTRUCTION STANDARDS, LATEST EDITION. ALL DUCTWORK SHALL BE 2 IN WG PRESSURE CLASS MINIMUM.
- ALL DUCTWORK JOINTS, LONGITUDINAL AND TRANSVERSE SEAMS, SHALL BE SEALED WITH WELDS, GASKETS, OR MASTIC ADHESIVE. MASTICS SHALL BE LISTED IN ACCORDANCE WITH UL 181A.
- FLEXIBLE DUCTWORK SHALL BE INSULATED AND SHALL BE TESTED IN ACCORDANCE WITH UL 181 LISTED. FLEXIBLE DUCTWORK SHALL NOT EXCEED 6'-0" IN LENGTH. PROVIDE WRAPPED RIGID ROUND DUCTWORK FOR TAKEOFFS IN EXCESS OF 6'-0".
- DUCTWORK DIMENSIONS LISTED ON THE DRAWINGS ARE CLEAR, INSIDE DIMENSIONS. WHERE DUCT LINE IS SPECIFIED, INCREASE THE OUTSIDE SHEET METAL DIMENSIONS TO PROVIDE THE CLEAR INSIDE DIMENSIONS SPECIFIED.
- ALL BRANCH DUCT TAKEOFFS SHALL BE 45° HIGH-EFF. TYPE AND SHALL HAVE A HEAVY DUTY MANUAL BALANCING DAMPER WITH MINIMUM 1/4" ROD AND LOCKING INDICATING QUADRANT. ACCEPTABLE MANUFACTURERS INCLUDE GREENHECK, POTTORFF, AND RUSKIN. LIGHT-DUTY DAMPERS THAT ARE INTEGRAL TO TAKE-OFF FITTINGS ARE NOT ACCEPTABLE.
- DUCTWORK INSULATION SHALL BE INSTALLED BY A QUALIFIED INSULATION CONTRACTOR WITH A MINIMUM OF 3-YEARS DOCUMENTED EXPERIENCE. INSULATION WORK SHALL BE COMPLETE WITH ALL EDGES SEALED, PER INDUSTRY STANDARDS, AND TO THE SATISFACTION OF THE ENGINEER.
- ALL CONCEALED ROUND SUPPLY, RETURN, OR OUTSIDE AIR DUCTS SHALL BE INSULATED WITH DUCT WRAP FIBERGLASS INSULATION WITH FSK VAPOR BARRIER FACING. JOHNS MANVILLE MICROLITE XG OR EQUAL BY KNAUF OR OWENS CORNING.
 - IN A CONDITIONED SPACE: 1.5" THICK (R-4.5)
- PROVIDE FLEXIBLE DUCT CONNECTIONS TO THE SUPPLY AND RETURN OF ALL MOTOR DRIVEN EQUIPMENT.
- PROVIDE DUCT TRANSITIONS AS REQUIRED TO CONNECT THE DUCTS TO THE EQUIPMENT CONNECTIONS.
- ELBOWS SHALL HAVE A MINIMUM RADIUS OF 1-1/2 TIMES CENTERLINE DUCT WIDTH. WHERE RECTANGULAR ELBOWS ARE USED, PROVIDE TURNING VANES.
- PROVIDE DUCT TRANSITIONS AS REQUIRED TO CONNECT THE DUCTS TO THE EQUIPMENT CONNECTIONS. INCREASE DUCT SIZES GRADUALLY, NOT EXCEEDING 15° DIVERGENCE WHEREVER POSSIBLE; MAXIMUM 30° DIVERGENCE UPSTREAM OF EQUIPMENT AND 45° CONVERGENCE DOWNSTREAM.
- ALL PENETRATIONS THROUGH THE FLOORS AND WALLS SHALL BE SLEEVED WITH GALVANIZED STEEL. SLEEVES SHALL BE LARGE ENOUGH TO ALLOW FOR INSULATION TO BE CONTINUOUS THROUGH THE SLEEVE. APPLY SEALANT TO BOTH SIDES OF PENETRATION TO COMPLETELY FILL ANNULAR SPACE.
- WHERE DUCTS PENETRATE A FIRE RATED ASSEMBLY PACK THE VOID WITH BACKING MATERIAL AND SEAL WITH UL LISTED FIRE CAULK TO MEET THE FIRE RATING OF ASSEMBLY PENETRATED. REFER TO ARCHITECTURAL PLANS FOR LOCATIONS AND TYPES OF FIRE RATED ASSEMBLIES.
- ALL AIR SYSTEMS SHALL BE BALANCED TO THE QUANTITIES SHOWN. THE BALANCING FIRM SHALL EITHER BE AABC OR NEBB CERTIFIED AND SHALL SUBMIT A BALANCE REPORT TO THE ENGINEER FOR REVIEW.
- THE MECHANICAL CONTRACTOR SHALL PROVIDE PRODUCT DATA FOR ALL THE MECHANICAL EQUIPMENT SCHEDULED, BALANCING DAMPERS, CONTROLS, DAMPERS, AND DUCT INSULATION. SUBMITTALS SHALL BE IN ELECTRONIC PDF FORMAT AND SENT VIA EMAIL TO THE ENGINEER. IF THE CONTRACTOR WANTS TO USE A MANUFACTURER NOT LISTED, THEY SHALL PROVIDE DOCUMENTATION TO THE ENGINEER FOR APPROVAL. ALL EQUIPMENT SUBMITTALS SHALL BE REVIEWED BY THE ENGINEER PRIOR TO THE START OF WORK.
- THE CONTRACTOR SHALL PROVIDE THE OWNER WITH (1) COPY OF ALL OPERATIONAL AND MAINTENANCE (O&M) MANUALS FOR EACH PIECE OF MECHANICAL EQUIPMENT. THE MANUAL SHALL INCLUDE: THE CONTRACTOR'S CONTACT INFORMATION, THE MANUFACTURER'S PUBLISHED O&M INSTRUCTIONS, THE APPROVED SUBMITTAL DRAWINGS, AND THE FINAL APPROVED TEST & BALANCE REPORT. COMBINE ALL THE MANUALS IN A 3-RING BINDER INDEXED FOR EACH PIECE OF EQUIPMENT. ALSO PROVIDE THE OWNER A CD WITH THE ENTIRE O&M MANUAL IN PDF FORMAT.
- THE CONTRACTOR SHALL PROVIDE THE OWNER WITH (1) FULL SIZE SET OF THE AS-BUILT MECHANICAL DRAWINGS WHICH SHALL SHOW THE ACTUAL LOCATIONS OF DUCTWORK, DAMPERS, GRDS, OR ANY OTHER DEVIATIONS FROM THE DESIGN DRAWINGS.
- THE CONTRACTOR SHALL PROVIDE OWNER TRAINING ON THE OPERATION AND MAINTENANCE OF THE MECHANICAL EQUIPMENT INCLUDING CONTROLS. PROVIDE NEW FILTERS IN THE EQUIPMENT AT THE END OF THE PROJECT.

SHEET INDEX:

M001	MECHANICAL NOTES, LEGENDS, & SCHEDULES
M101	MECHANICAL PLANS

MECHANICAL LEGEND

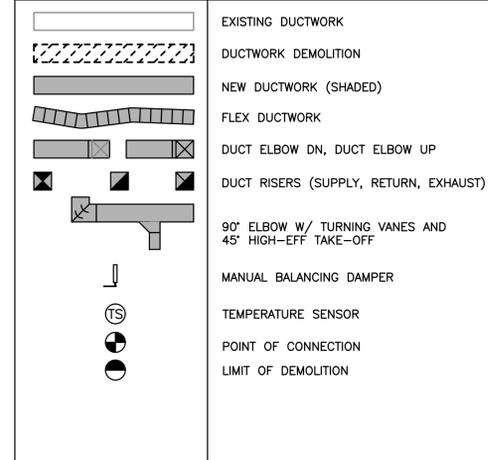

ABBREVIATIONS

AFF	ABOVE FINISHED FLOOR
BLW	BELOW
CD	CEILING DIFFUSER
CLG	CEILING
DN	DOWN
(E)	EXISTING
EA	EXHAUST AIR
EC	ELECTRICAL CONTRACTOR
EF	EXHAUST FAN
IFGC	INTERNATIONAL FUEL GAS CODE
IMC	INTERNATIONAL MECHANICAL CODE
IPC	INTERNATIONAL PLUMBING CODE
(N)	NEW
OBD	OPPOSED BLADE DAMPER
OA	OUTSIDE AIR
POC	POINT OF CONNECTION
RA	RETURN AIR
(REL)	RELOCATED
RG	RETURN GRILLE
SA	SUPPLY AIR
SD	SIDEWALL DIFFUSER
TA	TRANSFER AIR
TAB	TEST & BALANCE CONTRACTOR
TSTAT	THERMOSTAT
TYP	TYPICAL
W/	WITH
W/O	WITHOUT



POUDRE SCHOOL DISTRICT
 OLANDER ELEMENTARY SCHOOL
 5401 AUNTIE STONE STREET
 FORT COLLINS, CO 80526

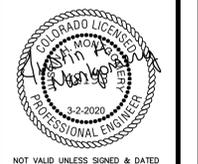

No.	Revision	Date

Sheet Title:
**NOTES,
 LEGEND, &
 SCHEDULES**

Project EC REST ROOMS	
Date 5/2/2020	Sheet M001
CONSTRUCTION SET	
Scale	

EXHAUST FAN SCHEDULE

TAG	MAKE & MODEL	CFM	SP (IN WC)	DD/BD	FRPM	VOLTAGE	WATTS	WEIGHT (LBS)	SPEED CONTROL	CONTROL	REMARKS
EF-1	GREENHECK SP-A110	100	0.125	DD	925	115/60/1	12	26	YES	A	ALL

1.) UL-507 LISTED 2.) MOTOR WITH THERMAL OVERLOADS 3.) INTEGRAL BACKDRAFT DAMPER 4.) ISOLATION KIT 5.) ROUND DUCT CONNECTOR 6.) CURB CAP W/ 18" TALL ROOF CURB AND BIRD SCREEN 7.) OR EQUAL BY LOREN COOK OR TWIN CITY FAN

A.) BASE BID: ON WITH LIGHTS, COORDINATE W/ E.C. FOR WIRING BID ALTERNATE #3: EXHAUST FAN TO BE CONTROLLED BY THE EXISTING BAS. SEE BID ALTERNATE SUMMARY, SHEET M001.

BID ALTERNATE NOTES:

- BASE BID: NEW RESTROOM EXHAUST FAN TO BE CONTROLLED ON WITH THE LIGHTS.
- BID ALTERNATE #3:
 - NEW RESTROOM EXHAUST FAN TO BE CONTROLLED BY THE BUILDING DDC SYSTEM IN LIEU OF THE STAND-ALONE SWITCHES.
 - EXISTING BUILDING DDC SYSTEM IS A SPYDER. APPROVED VENDOR IS BUILDING TECHNOLOGY SYSTEMS (BTS).

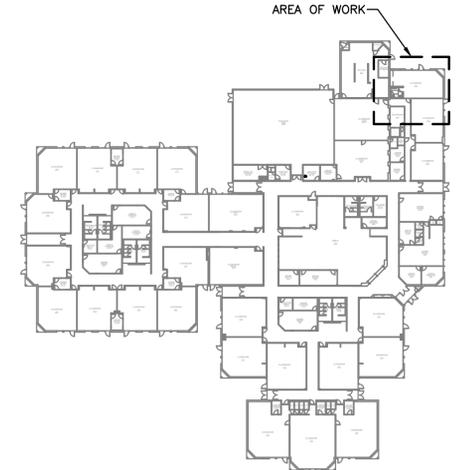

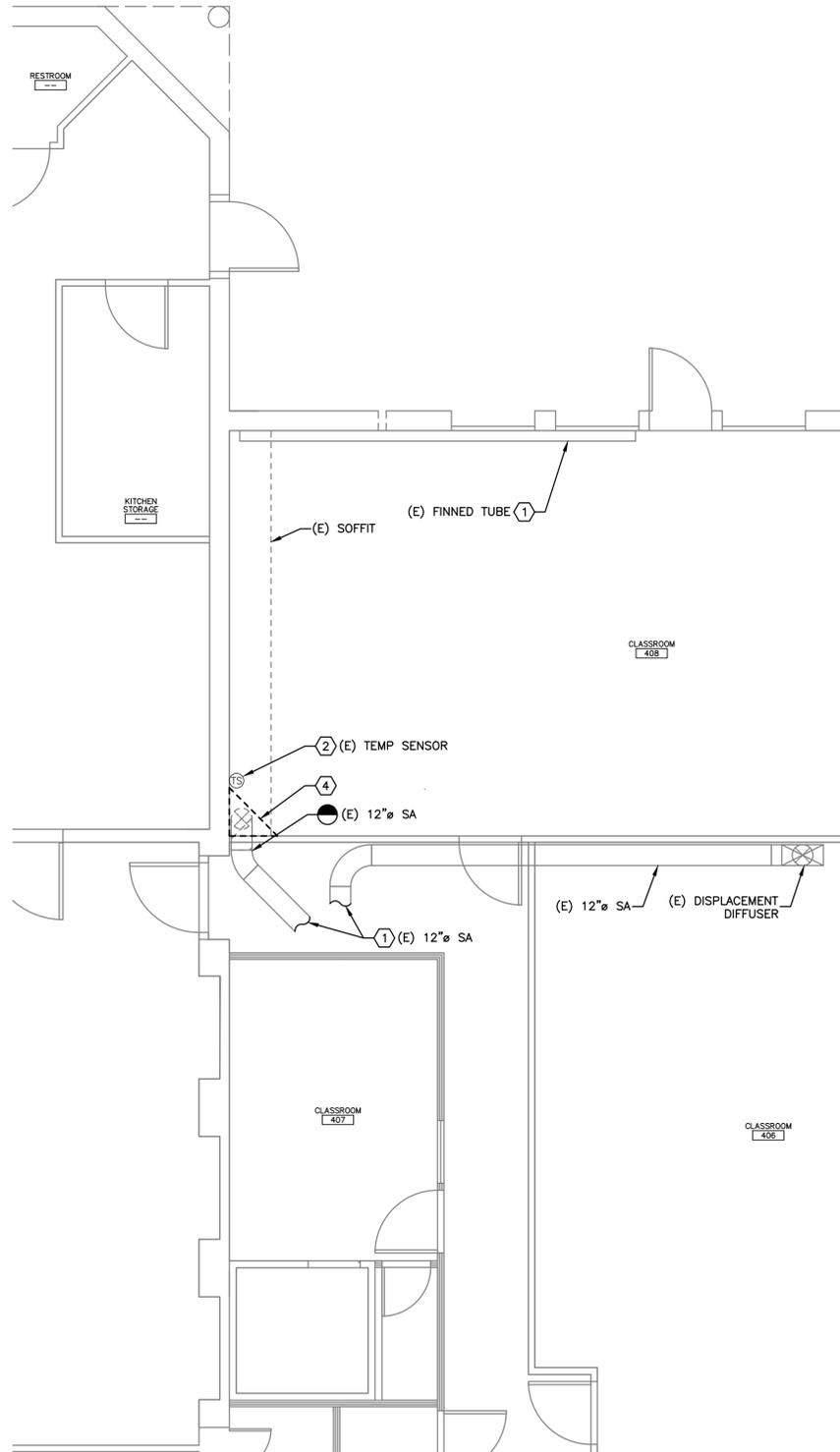

MECHANICAL DEMOLITION PLAN
 SCALE: 1/4" = 1'-0"
 4' 0' 4' 8'

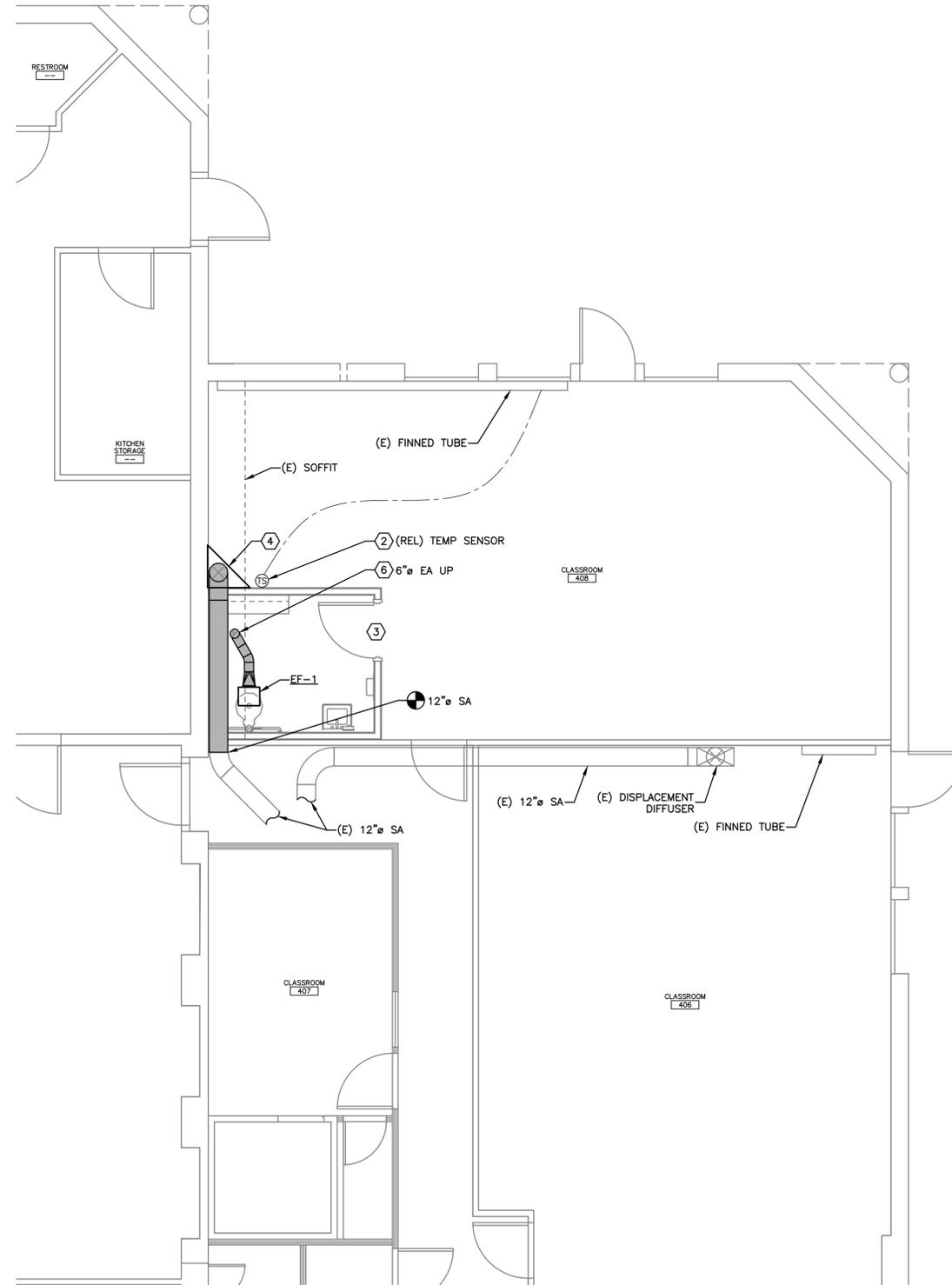

MECHANICAL REMODEL PLAN
 SCALE: 1/4" = 1'-0"
 4' 0' 4' 8'

FLAG NOTES:

1. EXISTING MECHANICAL WORK TO REMAIN AS IS.
2. REMOVE EXISTING TEMPERATURE SENSOR AND RELOCATE AS INDICATED ON THE PLAN.
3. COORDINATE W/ G.C. FOR A 3/4" DOOR UNDERCUT.
4. REMOVE AND RELOCATE EXISTING DISPLACEMENT DIFFUSER, PLENUM BOX, BALANCING DAMPER AND SUPPLY DUCT AS INDICATED ON THE PLANS. REBALANCE TO 270 CFM.
5. EXTEND THE EXISTING SUPPLY DUCT INSIDE THE EXISTING SOFFIT. RECONNECT TO EXISTING SUPPLY DUCT AND TO RELOCATED DIFFUSER.
6. EA DUCT UP THRU ROOF TO CURB CAP MOUNTED ON A ROOF CURB. COORDINATE W/ G.C. FOR NEW ROOF PENETRATION.

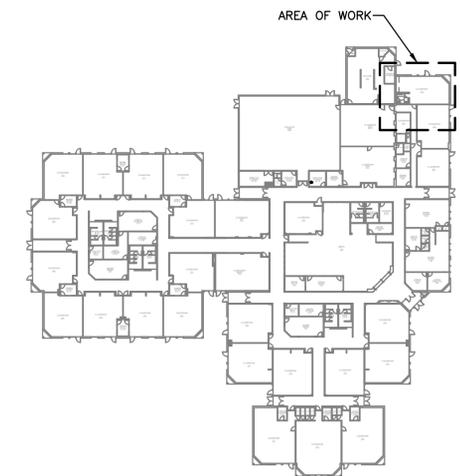

KEY PLAN
 SCALE: NONE



POUDRE SCHOOL DISTRICT
 OLANDER ELEMENTARY SCHOOL
 5401 AUNTIE STONE STREET
 FORT COLLINS, CO 80526

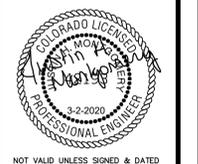

NOT VALID UNLESS SIGNED & DATED

No.	Revision	Date

Sheet Title:
MECHANICAL PLAN

Project:
EC REST ROOMS
 CONSTRUCTION SET
 Date: 5/21/2020
 Sheet: M101
 Scale: